

# Technical Datasheet

Product Code: 989100186732WRAS

Product Description: Arley 1000 x 500mm Kitchen Sink & Tap Pack



## Specification

Product Guarantee:	25 Years
Packaged Weight:	6.1 kg
Packaged Length (Metre):	1.04
Packaged Width (Metre):	0.54
Packaged Height (Metre):	0.16
Material:	Stainless Steel
Shape:	Rectangular
Projection:	500
Number Of Tap Holes:	1



## Key Features

- Sleek lines adds an element of style to your bathroom
- Manufactured from high quality stainless steel
- Features 1 tap hole suitable for mono basin mixer use
- Features lever control for a flawless level flow
- Comes complete with lever tap, waste & fixing clips
- Alternatively available in 860x500mm

## Technical Drawing

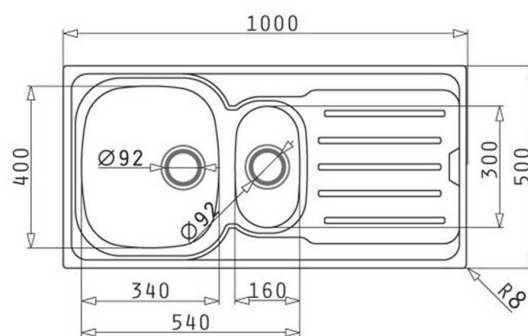

Dimensions: All measurements are in millimetres and are subject to normal manufacturing variations.

Due to a continuing development programme to improve design and performance, we reserve all rights to vary specifications without prior notice. Please note, all accessories are for photographic purposes only.