

ST PUMP15TN

Accessories 1.5 Bar Twin Ended Shower Pump Powered By Stuart Turner



Specification

Pump Type:	Single speed twin impeller
Power Supply:	230 Volts AC
Power Consumption:	385 Watts
Inlet Connection:	Flexible hose - 15mm push fit
Outlet Connection:	Flexible hose - 15mm push fit
Supply:	Suitable for gravity fed systems only
Max. Inlet Head:	10 Meters
Max. Head (closed valve):	15 Meters
Motor Rating:	30 minutes on / 30 minutes off
Max. Working Pressure:	3.0 Bar
Pump Rating:	1.5 Bar / 32 LPM
Max. Inlet Water Temperature:	65°C

Features:

- Twin impeller for boosting two water supplies.
- Fully automatic flow switch control - pump automatically starts when flow water exceeds 0.8 litres per minutes.
- Pump rated at 1.5 bar pressure equivalent to 15 meters head height
- Medium boost performance
- Low noise - fitted with anti-vibration feet
- Min. inlet water temperature - 4°C
- Max. inlet water temperature - 65°C
- Max. number of starts per hour - 60
- Max. ambient air temperature - 40°C
- Designed to be used with mixer showers only

Product Certifications:



WRAS Cert. Number: 2007386
WRAS Expiry Date: 31/07/2025

For more products, visit our website:
<http://www.bristan.com>



Dimensions (measurements in mm)

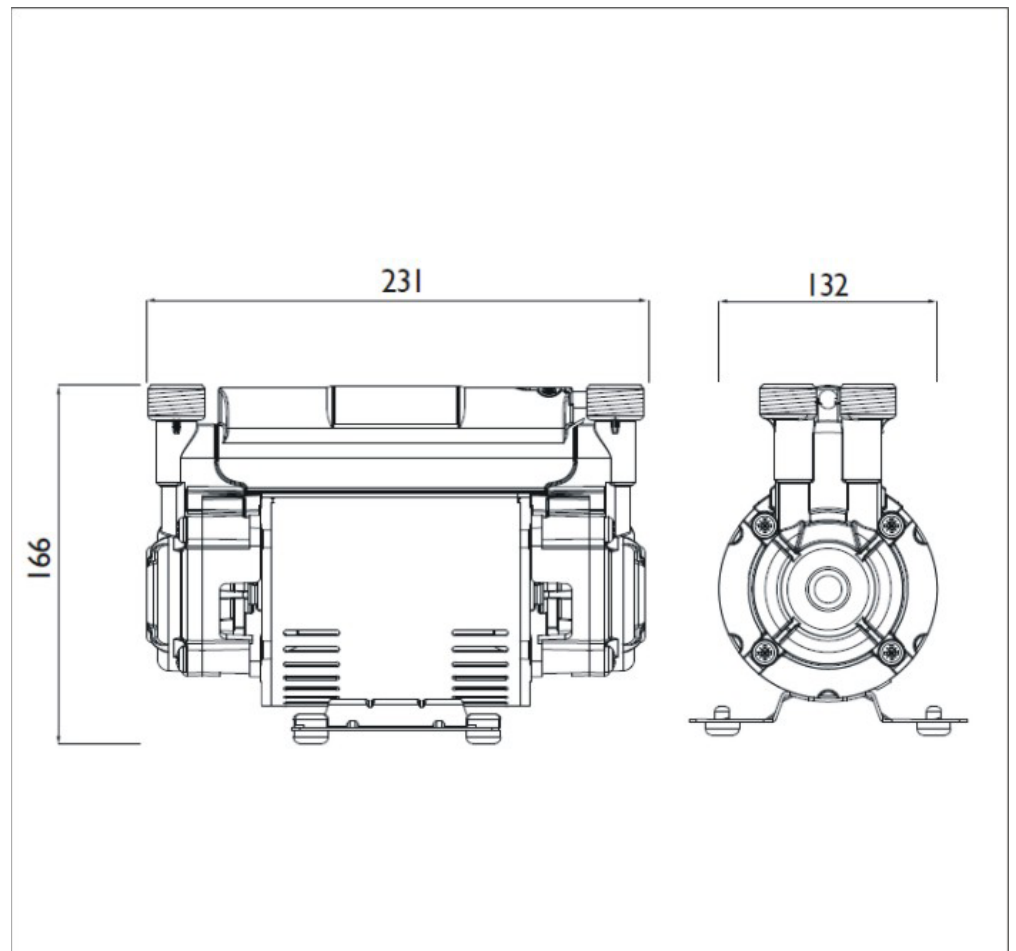

**TECHNICAL
DATA
SHEET**



BRISTAN

D5