

BRISTAN

Installation Instructions & User Guide

Please leave these instructions with the end user

Product Code: OP SHXVO ISOL EL C (D4)

Specifications

Dynamic Water Pressure
Min: 0.2 bar Max: 5.0 bar

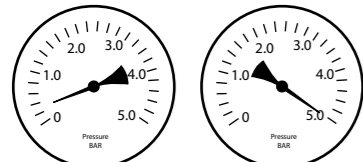

Maximum Static Pressure: 10.0 bar

Inlet Water Temperature
Cold Water Supply Hot Water Supply

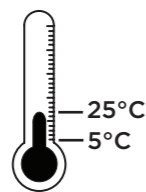

Min: 5°C Max: 25°C

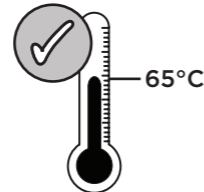

55-65°C Recommended

Inlet Dimensions

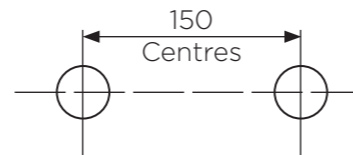

Inlet Connections
15mm Compression

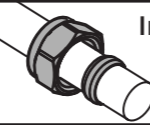

TMV Designations

TMV2: HP-SE & LP-SE

TMV3: HP-S & LP-S



IMPORTANT

The inlet hot water must be at least 10°C above the required blend temperature.

Tools You'll Need

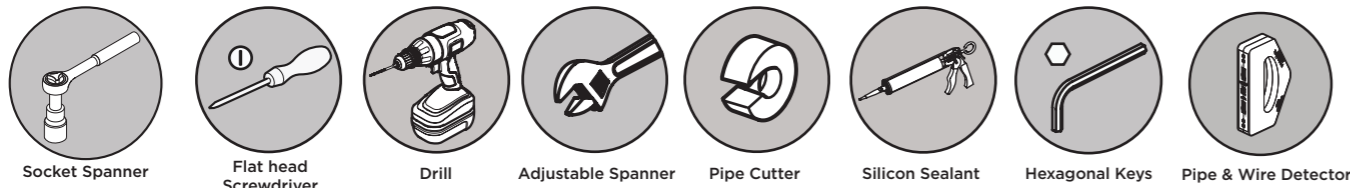

Prior to Installation

All products manufactured and supplied by Bristan are safe to use provided that they are installed, operated and receive regular maintenance in accordance with these instructions.

This product needs to be installed in accordance with, and meet the requirements of the Water Supply (Water Fittings) Regulations 1999 and current by-laws. For full Installation Requirements & Notes (IRN) please visit wras.co.uk/directory.

Isolation valves are incorporated into the wall mount to ensure ease of future maintenance. The hot and cold inlets come fitted with single check valves.

Before installing this product the water supply must be thoroughly flushed in order to remove any swarf, solder etc.

This product must not be modified in any way as this will invalidate the guarantee.

Full access must be made available for future maintenance/servicing purposes.

Before drilling into walls, check that there are no hidden electrical wires, cables or water supply pipes. This can be checked with the aid of an electronic detector.

If power tools are used do not forget to:

- Wear eye protection
- Unplug equipment after use

If in doubt, contact a registered plumber or your Local Water Authority or the Secretary of the Institute of Plumbing, address as follows:-

The Institute of Plumbing,
64 Station Lane,
Hornchurch,
Essex,
RM12 6NB, Tel: 01708 472791

Pack Contents

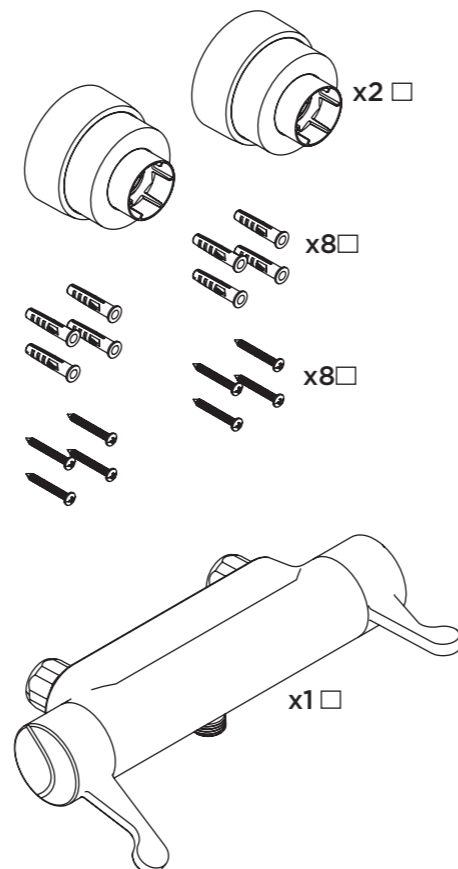

Valve Configuration

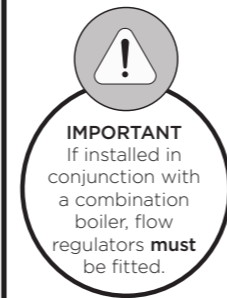

IMPORTANT
If installed in conjunction with a combination boiler, flow regulators **must** be fitted.

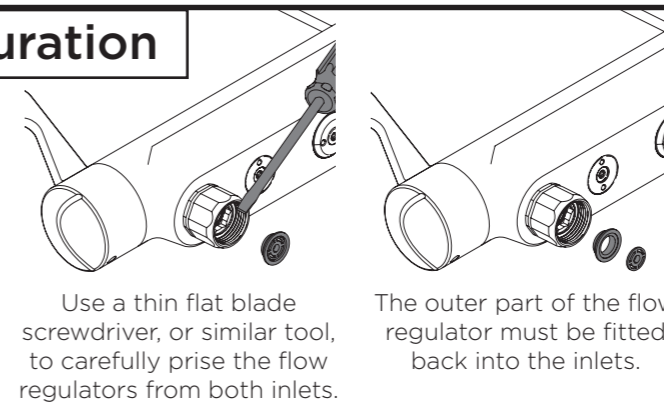

Use a thin flat blade screwdriver, or similar tool, to carefully prise the flow regulators from both inlets.

The outer part of the flow regulator must be fitted back into the inlets.

The shower valve is fitted with a 7 litre per minute flow regulator in each water inlet.

In the event that the shower valve is not installed with an instantaneous water heater/combination boiler, the flow regulators may be removed, however this will effect the TMV rating

Installation

1 Identify the required position of the valve and prepare the water supply pipes. Supply pipes should be 150mm apart.

Cut the pipework 21mm from the surface of the wall.

Using the backplate supplied with the wall-mount, mark and drill holes.

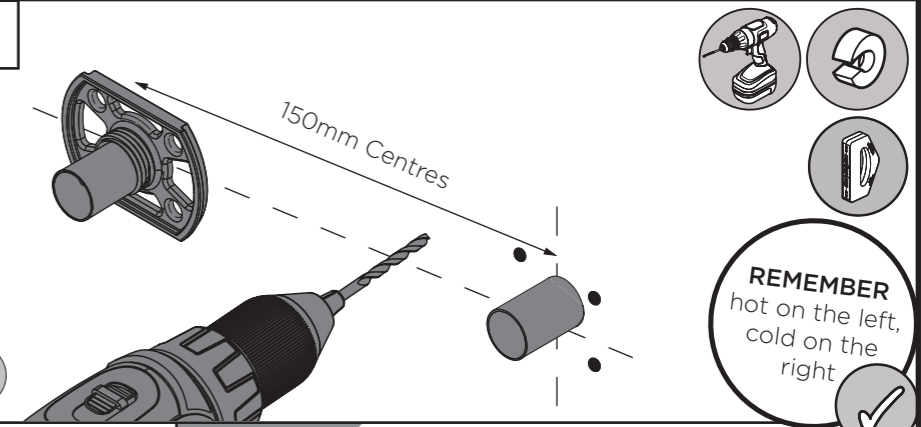

REMEMBER
hot on the left, cold on the right

2 Secure the rubber backplate and backplate into place.

3 Secure the isolator onto the backplate ensuring the olive is positioned over the pipework correctly.

4 Loosely place the shrouds over the outlets, ensuring the inlet thread is still accessible.

5 Secure the shower valve to the wall mount, ensuring filters are in place.

Open the isolation valves to turn on the water supply and check any joints and connections for leaks.

6 Pull the front & central shroud forward to secure into place on the valve. Ensure the rear shrouds conceal the inlets.

Operation

Isolation

To Isolate the valve, pull the shroud forwards to access the isolator.

Once finished, push the shrouds back into place.

Maintenance - Cartridge Cleaning

1

Remove the temperature control handle and plastic stop.

Unscrew the locking nut anti-clockwise and remove the cartridge from the valve.

2

Remove O-rings and soak all components in de-scaler and wash off in clean water. Examine all seals and replace if needed. Use WRAS approved silicon based grease on all seals.

3

Reverse stages 1&2 to replace the cartridge, plastic stop, locking nut & cartridge.

IMPORTANT
Isolate the water supply before starting!

Adjusting The Temperature

1

Turn the flow of water on, undo the grub-screw and remove the handle **without** removing the plastic stop.

2

Turn spline to clockwise to decrease the temperature, anti-clockwise to increase. Check and adjust until the required temperature is achieved.

3

Replace the handle, ensuring the plastic temperature stop is in the same position as when removed. Replace grub screw & cap.

For the full TMV requirements, refer to the enclosed TMV2&3 Service booklet.

Thermal Flushing

1

Close the cold water isolator screw by turning clockwise, and open the hot water flushing screw by turning anti-clockwise.

2

Turn the flow of water on. Hot water will flush the shower valve removing the build up of bacteria.

3

Turn the flow of water off by turning the handle to the 'off' position.

4

Reverse step 1 to open the cold water isolation and close the hot water bypass.

General Cleaning

Bristan products are made from premium materials, with hand polishing and electroplated finishes.

Your taps or shower should be regularly cleaned with warm water, a mild pH-neutral liquid soap, and polished with a soft cloth. Any residues from soap, toiletries etc. should be rinsed off straight after use.

Household bleaches and cleaners contain harsh chemicals and may damage the surface finish. Avoid using abrasive cloths, scouring pads, scrub sponges, steel wool or anything similar. Some surfaces such as nickel and pewter may be affected by the dye found in some cloths, so it is also important to avoid hanging cloths on spouts.

Troubleshooting		
Symptom	Cause(s)	Remedy
No flow or low flow rate	Partially closed isolation valve.	Open isolation valve.
	Instantaneous water heater cycles on and off as flow rate or pressure is too low.	Increase water flow rate or pressure through system.
	Head of water is below the minimum distance required.	Refer to your the Specification for the minimum working pressure/distance required.
	Hot or cold water being drawn off elsewhere causing pressure changes or instantaneous boiler temperature changes.	Do not use other water outlets when using the taps.
	Airlock or partial blockage in the supply pipe work or hoses.	Flush through pipe work to ensure removal of debris and any airlocks.
Water supply failure	Investigate water supply. Check your plumbing and heating systems for any faults.	
Water dripping from shower	This is normal for a short time after using the shower.	This is caused by residual water tension, the build up of water in the shower.
	If water continues to drip, possibly due to the ceramic disc valves/cartridge	Refer to the Maintenance section or visit www.youtube.com/BristanTV to watch the procedure.
Shower does not turn on	Closed isolation valve.	Open isolation valve.
	Mains water supply turned off.	Turn on mains water supply.
Outlet temperature too hot / cold	Inlet filter is partially blocked	Check insert filters for any blockages and clean as necessary.
	Installation conditions outside operating parameters.	Refer to Installation Requirements section. Service the shower as recommended, refer to maintenance section. Refer to adjusting the temperature section.
Water temperature too cold	Hot water temperature is less than 10°C above the required blend temperature.	Adjust hot water temperature, or wait for water to heat if a stored system is used.
	Instantaneous water heater not igniting because the water flow rate is too low.	Increase water flow rate through system. Check inlet filters and clean or replace. Contact the boiler manufacturer.
	Instantaneous water heater not igniting because the water ressure is too low.	Increase water pressure through the system. Contact the boiler manufacturer.
Only hot or cold water from shower valve outlet	Inlet water supplies are reversed (hot to cold supply)	Check the connections are the right way round. Hot on the left, cold on the right as viewed from the front. Rework pipe work as necessary
	Inlet filter is partially blocked.	Clean or replace, flush through pipe work before refitting.

Servicing Intervals

To reduce the build up of lime scale and to ensure this shower works to its maximum performance we recommend this shower is serviced every 6-12 months depending on the hardness of your water.

Spare Parts

To replace any spare parts for your shower why not scan the below QR Code and search for your product.



At Bristan, we want to make things as easy as possible for our customers. That's why we offer solid guarantees on all our products, effective from the date of purchase, to give you peace of mind.

To start your free guarantee simply scan the QR code and register your product. Alternatively visit www.bristan.com/register.

For any other queries, please call our Customer Service on 0330 026 6273 where our expert team of advisors will be able to offer you any help and advice.

For full guarantee terms and conditions visit www.bristan.com/guarantees.

