

Cool to Touch Bar Shower with Diverter Featuring Aurajet™ AOKCTSDEF

Installation Instructions & Maintenance Guide

Your product has a high quality finish and should be treated with care to preserve the visible surfaces.

Never use abrasives or abrasive cleaning agents to clean this product. Clean regularly with contamination free warm soapy water and a damp soft cloth. Do not use products containing chlorine bleach or hydrochloric acid as these can damage the product. Always rinse the product thoroughly after cleaning to remove cleaning products that can damage the shower.

Your product comes with a 5 year guarantee, This includes 2 years parts and labour followed by a further 3 years parts only, subject to the following:

Proof of purchase will be required

The guarantee does not cover faults or damage caused by incorrect installation and/or maintenance, ordinary wear and tear, water composition etc. including:

Supply pipes reversed, Incorrect pressure or temperature, *Incorrect use, Foreign bodies and/or scale due to the water composition, Incorrect cleaning.

We have a policy of continuous improvement and reserve the right to change specifications without notice.

METHVEN UK LIMITED
METHVEN EXPERIENCE CENTRE
3/3A STONE CROSS COURT
YEW TREE WAY
GOLBORNE
WARRINGTON
WA3 3JD
UNITED KINGDOM

TEL: 0800 195 1602
FAX: +44 (0) 1942 680 190
E: sales@uk.methven.com
methven.com

P16

Technical Specifications:

Supply:

Suitable For High Pressure Systems

Working Pressure:

1.5bar - 5.0bar

Operating Temperature:

Hot: Max 65°C

Cold: Min 5°C

Inlet Connections:

15mm Compression

Cartridge/Valve Type:

Thermostatic



METHVEN
www.methven.com

CONTENTS

Line Drawing..... 3
Parts Reference Drawing 4
Parts Reference Information..... 5
General Characteristics..... 6
Operating Specifications..... 7
Recommended Outlet Temperature..... 7
Installation..... 8
Commissioning..... 11
In Service Testing..... 13
Filter Washer Cleaning..... 15
Cleaning..... 16
Guarantee..... 16

PLEASE RETAIN THIS DOCUMENT FOR FUTURE REFERENCE

IMPORTANT: Please read all of the instructions before installation.

Depending on the results of the above tests, several possibilities exists:

- a) If no significant change(e.g.<1) in mixed water temperatures are recorded between commissioning and 6-8 week testing, or between commissioning and 12-15 weeks testing the next in-service test can be deferred to 24-28 weeks after commissioning.
- b) If small changes (e.g. 1-2) in mixed water temperatures are recorded in only one of these periods, necessitating adjustment of the mixed water temperature, then the next in-service test can be deferred to 24-28 weeks after commissioning.
- c) If small changes (e.g. 1-2) in mixed water temperatures are recorded in both of these periods, necessitating adjustment of the mixed water temperature, then the next in-service test can be carried out at 18-21 weeks after commissioning.
- d) If significant changes (e.g. >2) in mixed water temperatures are recorded in either of these periods, necessitating service work, then the next in-service test should be carried out at 18-21weeks after commissioning.

The general principle to be observed after the first 2 or 3 in-service tests is that the intervals of future tests should be set to those which previous tests have shown can be achieved with no more than a small change in mixed water temperature.

FILTER WASHER CLEANING

It is advised that this should be carried out by a qualified person

- 1 Isolate both hot and cold mains supplies
- 2 Undo the nuts on both hot and cold inlet unions and remove the filter washers.
- 3 Wash the filter washers thoroughly under running water. Use a suitable brush to remove all debris.
- 4 Refit into hot and cold inlets and tighten nuts
- 5 Turn on hot and cold mains supplies and check for leaks

- c) Record the temperature of the mixed water at a smaller draw-off rate, which shall be measured.

If the mixed water temperature has changed significantly from the previous test result (e.g.>1) record the change and before re-adjusting the mixed water temperature check:

- a) That any in-line or integral strainer are clean
- b) Any in-line or integral check valves or other anti-back siphon age devices are in good working order
- c) Any isolating valves are fully open

With an acceptable mixed temperature, complete the following procedure:

- a) Record the temperature of the hot and cold water supplies
- b) Record the temperature of the mixed water at the largest draw-off flow rate
- c) Record the temperature of the mixed water at the smaller draw-off flow rate, which shall be measured
- d) Isolate the cold water supply to the mixing valve and monitor the mixed water temperature.
- e) Record the maximum temperature achieved as a result of (d) and the final stabilised temperature
- f) Record the equipment, thermometer etc. used for the measurements

If at step (e) the final mixed water temperature is greater than the values in the table and/or the maximum temperature exceeds the corresponding value from the previous results by more than about 2, the need for service work is indicated.

NOTE: In-service tests should be carried out with a frequency, which identifies a need for service work before an unsafe water temperature can result. In the absence of any other instruction or guidance, the procedure described in Annex F may be used

Annex F (informative)

General

In the absence of any other instruction or guidance on the means of determining the appropriate frequency of in-service testing, the following procedure may be used:

- a) 6to8 weeks commissioning carry out the tests detailed in in-service tests"
- b) 12 to 15 weeks after commissioning carry out the tests detailed in "in-service tests"

P14

LINE DRAWING

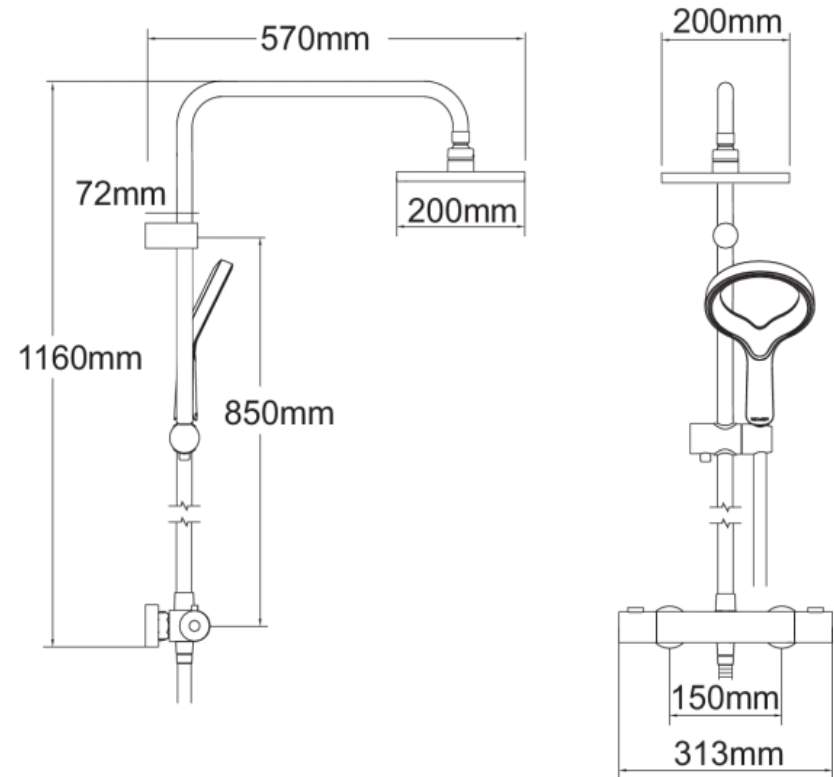

P3

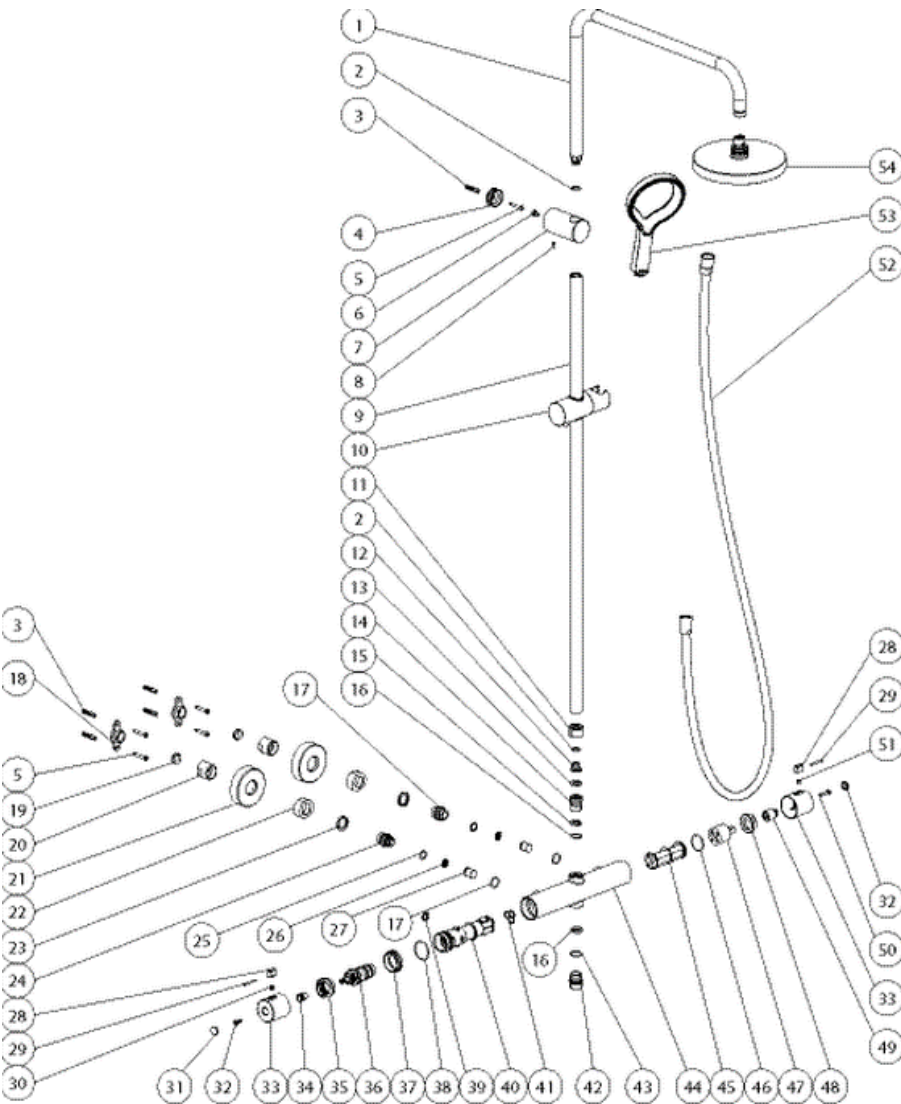

P4

5 Allow the shower to run at this maximum temperature setting until the water temperature has stabilised.

6 A final temperature check should be made and that the mixed water temperature at the terminal fitting must never exceed 46°C.

It is a requirement that all TMV2 approved valves shall be verified against the original set temperature results once a year to ensure continued good performance, failure to regularly maintain the Thermostatic mixing valve may lead to poor flow, fluctuations in temperature and in some cases complete failure.

The mixer has been set in the factory under balanced pressures at 38°C. Where conditions are different from the above the temperature of the mixed water may vary from setting. You can adjust the calibration of the mixer to suit individual requirements.

- 1 Turn temperature handle to fully hot.
- 2 Remove the handle cap and the screw and pull the handle from valve
- 3 Turn the spindle on the thermostatic cartridge until the desired temperature is reached. (Always maintain the 10°C difference between supply and mixed).
- 4 Once the temperature is reached, replace the handle so that the stop is in the maximum position, replace screw and handle cap.

Re-calibration should only be carried out when absolutely necessary.

In Service Testing

Purpose

The purpose of in-service test is to regularly monitor and record the performance of the thermostatic mixing valve. Determination in performance can indicate the need for service work on the valve and/or the water supplies.

Procedure

Using the same measuring equipment or equipment to the same specification as used in the commissioning of the valve, adjust the temperature of the mixed water in accordance with the manufacturer's instructions and the requirement of the application. Carry out the following sequence:

- a) Record the temperature of the hot and cold water supplies
- b) Record the temperature of the mixed water at the largest draw-off flow rate

P13

3 The supply temperatures are within the thermostatic valve operating range

If all these conditions are met, proceed to check factory setting.

- 1 Start the water flow by rotating the flow control (right hand side) anticlockwise.
- 2 This product has flow override button on the flow control which allows for reduced flow. To activate full flow, press the button and continue turning the handle.

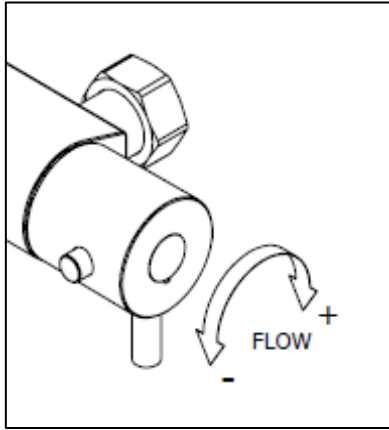

3 Make sure that the hot and cold water suppliers are fully open, at normal temperature and pressure and are within the requirements as stated.

4 Make sure the temperature control (left hand side) is at the maximum temperature setting. This product has a temperature override button, to access temperature above the normal comfortable showering temperature, press the button and continue turning the handle.

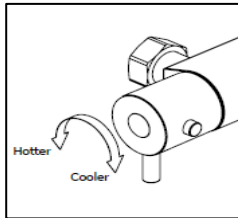

PARTS REFERENCE DRAWING/INFORMATION

Part	Description	Part	Description
1	Upper Drencher Arm	28	Button
2	O-Ring	29	Pin
3	Expansion Pipe	30	Spring
4	Fixed Seat	31	The Flap
5	Screw	32	Screw
6	Screw	33	Temperature Control knob
7	Wall Bracket	34	Splined Sleeve
8	Screw	35	Temp Bottom Ring
9	Shower Rail	36	Temperature Control Valve
10	Slider	37	Nut
11	Locking Nut	38	O-Ring
12	Connection	39	Sealing Gasket
13	Washer	40	Sleeve
14	Outlet Elbow	41	Sealing Ring
15	Sealing Gasket	42	Hose Connector
16	O-Ring	43	O-Ring
17	Connector	44	Bar Valve Main Body
18	Fixed Seat	45	Sleeve
19	Sealing Ring	46	O-Ring
20	Connector	47	Control & Diverter Valve
21	Flange Cover	48	Nut
22	Nut	49	Sleeve
23	Gasket	50	Screw
24	Connector	51	Copper Ring
25	Circlip for hole A	52	Brass Hose
26	Filter	53	Handset
27	Check Valve	54	Shower Head

GENERAL CHARACTERISTICS

Methven recommends this product is installed by a licensed plumber in compliance with all relevant Water Authority Regulations. If you are unsure as to what the regulations require, you can contact your Local Water Authority or the institute of Plumbers for further details.

This product is safe provided it is installed, used and maintained in accordance with these instructions and recommendations.

Do not choose a position where the thermostatic bar valve could become frozen.

Do not allow the inlet pressure or flow rates to operate outside the operating conditions

Do not connect the thermostatic bar valve to a gravity hot supply and a mains cold supply or vice versa.

Do not subject the thermostatic bar valve to a water temperature above 85°C during installation, use, maintenance or disinfection.

Do not use jointing compounds on any pipe fittings for the installation

Do not solder fittings near the unit as heat transfer along the pipework could damage the bar valve.

The layout and sizing of pipework must be such that nominally equal inlet supply pressures are achieved and the effects of other draw-offs are minimised.

The hot water pipe entry must be made to the left-hand side inlet, marked with a red dot.

Suitable isolating valves (complying with Water Regulations and Bylaws) must be fitted on the hot and cold water supplies as close as practicable to the inlets of the thermostatic bar valve. These isolating valves must be accessible to provide an independent means of isolating the water supplies should maintenance or servicing be necessary.

Before connecting the thermostatic bar valve, water should be flushed through the system to remove all debris that might otherwise damage the valve.

27 To fit the trim plates, screw on to the threaded insert until it reaches the finished wall lining and align accordingly.

At this stage the pipe should be flushed of any debris. Failure to do so may result in the filter of the bar valve becoming prematurely blocked and reduce its performance.

28 Ensuring seals and filters are correctly located in the inlet unions of the bar valve, screw the unions of the bar valve to the easy fix connectors and tighten.

29 Turn on the hot and cold water supplies and check for leaks.

To Fit The Shower Rail Kit

1 Connect the shower hose to the handset and the bar shower outlet connector at the other end.

2 Fit the shower handset into the handset holder of the shower rail kit, place the shower rail kit assembly against the wall to find a suitable place to fix the shower rail kit (Note: when deciding where to fix the shower rail kit, please ensure that the shower hose will not be stretched or subjected to any unnecessary tight bends).

3 Once a suitable place is found, mark the position of the shower rail kit brackets. Remove the shower handset and fix the shower rail kit to the wall taking care of any hidden pipes when doing so.

4 Place the handset into the handset holder of the shower rail kit.

5 Ensuring the bar shower mixer is in the off position, turn on both hot and cold water supplies and check for leaks.

COMMISSIONING

As the installed supply conditions are likely to be different from those used in factory testing it is appropriate, at commissioning, to carry out some simple checks and tests on the thermostatic bar valve to provide a performance reference point for future verification.

Check that:

1 The designation of the thermostatic bar valve matches the intended application.

2 The supply pressures are within the thermostatic valve operating pressures.

To fix the second mounting bracket and ensure the bar valve is positioned squarely on the wall

- 16 Take the second mounting bracket in your hand loosely fit the thread inset. Take this loose assembly and screw this to the bar valve.

This will be used as a template to ensure that the correct centres are achieved and the thermostatic bar valve is installed squarely.

- 17 Loosely screw the other bar valve connection to the mounting bracket assembly affixed to the wall previously ensuring the second expose pipe slides into the loosely assembled mounting bracket attached to the thermostatic bar valve.
- 18 Taking care not to damage the surface of the bar valve, use a spirit level to line up the bar valve squarely. Ensuring the mounting bracket is against the wall, use the mounting bracket as a template to mark the positions of the holes to be drilled and plugged.
- 19 Remove the shower mixer assembly from the wall
- 20 Unscrew the loosely assembled mounting bracket and threaded connector from the thermostatic bar valve.
- 21 Drill and plug the wall in positions as previously marked.

Ensure you use the correct type of wall plugs to suit your particular installation conditions.

- 22 Place the mounting bracket over the pipe.
- 23 Place the olive over onto the exposed pipe.
- 24 Take the remaining threaded connector, slide it over the pipe and loosely wind the threaded connector into the mounting bracket.
- 25 Screw the mounting bracket to the wall
- 26 Using two spanners, one located on the mounting bracket and the other located on the threaded adaptor, tighten the thread adaptor to the mounting bracket.

Ensure that two spanners are used to ensure that you do not tighten the assembly against the mounting bracket screws. Failure to do so may result in the mounting becoming loose.

OPERATING SPECIFICATIONS

This valve is suitable for High Pressure water heating systems provided it is installed correctly

	High Pressure
Maximum Static Pressure - Bar	10 bar
Flow Pressure, Hot & Cold - Bar	1.5 to 5
Hot Supply Temperature - °C	55°C to 65°C
Cold Supply Temperature - °C	< 25°C

NOTE: Valves operating outside these conditions cannot be guaranteed by the scheme to operate as Type 2 valves.

Operating pressure on hot and cold line should be kept as balanced as possible in order to assure maximum efficiency.

The valves designation of use is for High Pressure (HP-S) BS EN1111 and the recommended mixed water outlet for showers at point of discharge is 41°C

If a water supply is fed by gravity then the supply pressure should be verified to ensure the conditions of use are appropriate for the valve.

The check valves with strainers are inserted in the inlet connections in order to prevent backflow.

RECOMMENDED OUTLET TEMPERATURES

The BuildCert TMV Scheme recommends the following set maximum mixed water outlet temperatures for use in all premises:

44°C for bath fill but see notes below;

41°C for showers

41°C for washbasins

38°C for bidets

The mixed water temperature must never exceed 46°C

The maximum mixed water temperature can be 2°C above the recommended maximum set outlet temperatures.

INSTALLATION

Important points to note before commencing installation of your concealed shower mixer. You should have:-

- 1 Check the contents of the box and all parts are present and correct.
- 2 Check to ensure the minimum operating conditions can be met.
- 3 The correct tools to perform a trouble free installation
- 4 Considered the surrounding environment where the installation is to take place and any potential hidden dangers.
- 5 Isolate both the hot and cold water supplies

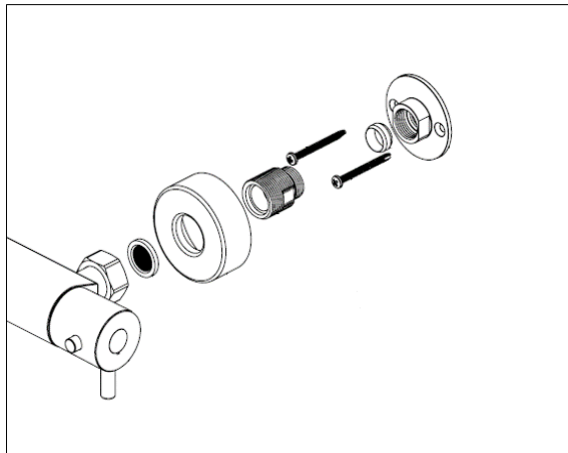

Installing The Easy Fit Connections and Valve

- 1 Prepare the Hot and Cold supply pipes at 150mm centres.
- 2 Ensure the holes for the pipes are not made too big as this will affect drilling of the screw holes for the mounting brackets.
- 3 Ensure that there is approximately 22mm of pipework left exposed proud of the finished tiled wall to establish the correct installation connection.
- 4 Apply an appropriate amount of sealant between the pipe and wall lining to create a watertight seal.

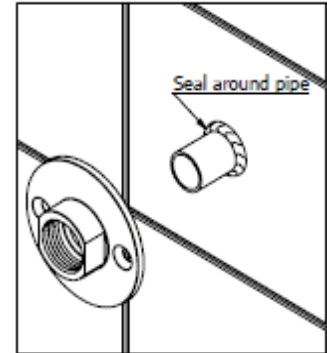

It is the responsibility of the installer to ensure a waterproof seal is achieved between the product and mounting surface.

- 5 Place the mounting plate over the pipework
- 6 Place the olive over onto the exposed pipe.
- 7 Take one of the threaded connectors, slide the connector over the pipework and loosely fit the threaded connector into the mounting bracket. This will ensure that the pipework is central to the mounting bracket.
- 8 Using the mounting bracket as a template, mark the positions of the holes to be drilled.
- 9 Remove the threaded connector, slide the mounting bracket and olive off the pipework
- 10 Drill and plug the wall in position as previously marked, **Note: Ensure you use the correct type of wall plugs to suit your particular installation conditions.**
- 11 Place the mounting bracket over the pipework
- 12 Place the olive over onto the exposed pipe.
- 13 Take one of the threaded connectors, slide the connector over the pipework and loosely fit the threaded connector into the mounting bracket.
- 14 Screw the mounting bracket to the wall
- 15 Using two spanners, one to be located on the mounting bracket and the other to be located on the threaded adaptor then tighten the thread adaptor to the mounting bracket. **Note: Ensure that two spanners are used to ensure that you do not tighten the assemble against the mounting bracket screws. Failure to do so may result in the mounting becoming loose.**