

Warranty Information

Proof of purchase will be required.

The guarantee does not cover faults or damage caused by incorrect installation and/or maintenance, ordinary wear and tear, water composition, etc.

*Please see www.deva-uk.com for full terms and conditions of warranty

Cleaning

Your product has a high-quality finish and should be treated with care to preserve the visible surfaces. Never use abrasives or abrasive cleaning agents to clean this product clean regularly with contamination free warm water and a damp soft cloth. Do not use products containing chlorine bleach or hydrochloric acid as these can damage the product.

We have a policy of continuous improvement and reserve the right to change specifications without notice.

METHVEN UK LIMITED
METHVEN EXPERIENCE CENTRE
3/3A STONE CROSS COURT
YEW TREE WAY
GOLBORNE
WARRINGTON
WA3 3JD
UNITED KINGDOM

INST-GTSDEFBK- 13/09/2022

TEL: 0800 195 1602
FAX: 0844 406 8690
EMAIL: sales@uk.methven.com
www.deva-uk.com
www.methven.com

Thermostatic Diverter Shower GTSDEFBK Installation & Maintenance Guide

Technical Specification

Working Pressure:

Min: 0.3 Bar

Max: 5.0 Bar

Operating Temperature:

Hot: 65°C

Cold: 5°C

Inlet Connections:

15mm Compression

Features:

- 38°C temperature hot stop with override facility
- Built in diverter to fixed head/3 mode handset
- Riser height can be adjusted to suit your bathroom
- Double interlocked 1.5m hose
- Includes easy fit connections
- Matte Black Finish



Contents

Congratulations on your purchase of your new Deva by Methven Thermostatic Diverter Shower. Our fitting instructions have been created with you in mind to provide you with all the information you require and, if you need any further help, please don't hesitate to contact our customer care team on 0800 195 1602.

General Safety Information 3

Line Drawing 3

Product Breakdown 4

Product Breakdown 4

Installation Requirements 6

Installation 6

Troubleshooting 7

Warranty Information 8

Cleaning 8

Troubleshooting

FAULT	POSSIBLE CAUSE
Shower only runs out hot or cold after installation	1.Hot and Cold supplies have been plumbed the wrong way around; 2.Faulty Thermostat
Shower does not run hot enough	1.Check hot water supply temperature; 2.Blockage on the hot supply.
Low or no flow	1.Possible blockage in the system; 2.C operating conditions are incorrect; 3.Valve shut off has been acclimated due to a pressure drop in either the cold or hot supplies.
Leaking when in the position	1.Debris in flow control cartridge; 2.Faulty flow control cartilage
Fluctuating flow	1.Dynamic inlet pressure are not transmitted; 2.Faulty thermostatic cartridge
Hot water in cold supply or vice verse	1.Check and clean non-return valves

Temperature Adjustment/Commissioning

- 1) Turn the temperature control to the mixed position (marked 38°C on the handle).
- 2) Turn on the water to the bath filler and using a thermometer take a temperature reading.
- 3) If the temperature requires adjustment prise the cap out of the centre of the temperature control handle.
- 4) Remove the handle screw and pull the handle off the top of the thermo-static cartridge.
- 5) With the handle removed rotate the spindle, anti-clockwise to increase clockwise to decrease.
- 6) Once the desired temperature is achieved re-fit the handle in the mixed position, so that the handle cannot be rotated any further clockwise without depressing the override button.

Commissioning and Testing

The thermostatic mixing valve is factory set to the indicated temperature. Check the product after installation to ensure that it operates at the correct outlet temperature. A temperature difference of at least 10°C should be maintained between the mixed and system hot water.

After commissioning carry out a cold water failure test to ensure the valve is operating correctly.

If some adjustment is required to the temperature, this should only be carried out when necessary, by a competent person.

The valve should be tested to ensure correct operation at commissioning and thereafter at stated intervals decided by the user but never greater than a 12 Monthly period.

The testing will only require a normal thermometer with a scale greater than 65°C. The temperature sensitive element of the thermometer should always be fully inserted into the water flow.

Measure the mixed water temperature.

Carry out a cold fail/safe shut off test by using the isolation valve to shut off the water to the cold supply.

Wait 5 seconds, if the water is still flowing, check that the water temperature is below 46°C. The flow of water should reduce to a trickle or stop completely. Open the cold water isolation valve and measure mixed water temperature.

If there is no significant change from the original settings and the fail/safe shut off is functioning the valve is working correctly and no further service is re-quired.

If the outlet temperature has drifted by more than 2°C, or if the fail/safe function does not work, a full service or re-commissioning is required.

The manufacturer of the valve recommends that in these circumstances you contact a competent person for servicing or ring Methven on 0800 195 1602 for further advice.

Please keep these instructions for future reference and request of replacement parts

General Safety Information

Please read all of the instructions before installation.

Methven recommends this product is installed by a competent person in compliance with all relevant regional regulations.

Remove all packaging and check the components for damage before starting installation.

This product **must** not be modified in any way as this will invalidate the guarantee.

It is the responsibility of the installer to ensure a waterproof seal is achieved, after installation all connections must be checked for leaks.

All outlets used primarily for personal hygiene shall deliver water at a safe temperature as per regional regulations.

Line Drawing

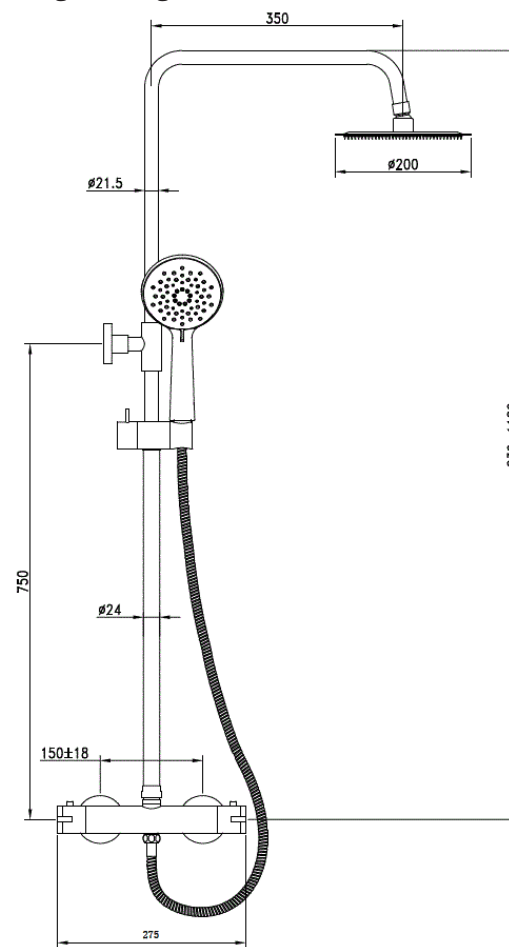

Product Breakdown

Check All components are present prior to starting installation.

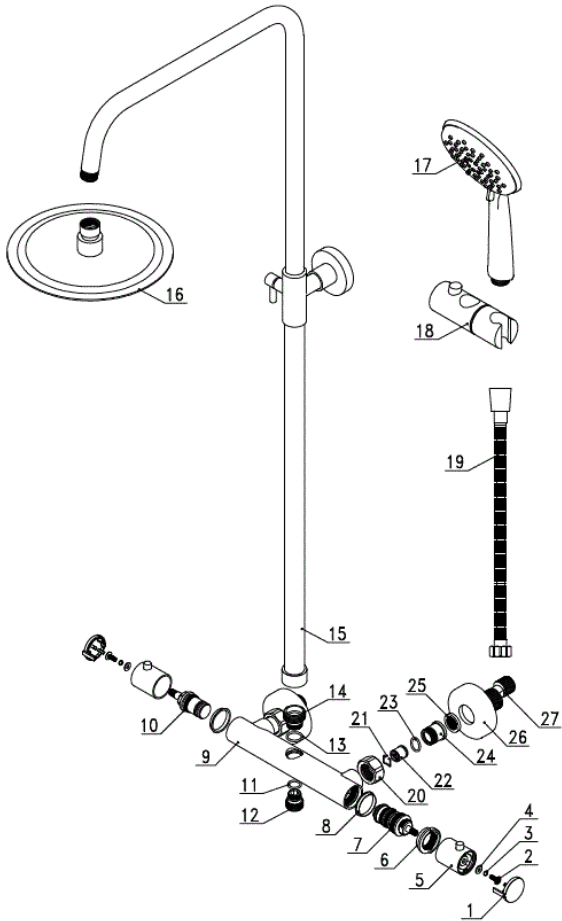

Item Number	Description	Qty	Item Number	Description	Qty
1	Handle Cover	2	15	Riser Rail	1
2	Screw	2	16	Fixed Shower Head	1
3	Washer	2	17	Shower Handset	1
4	Washer	2	18	Handset Holder	1
5	Handle	2	19	Flexible Shower Hose	1
6	Sleeve Gear	1	20	Hexagonal Nut	2
7	Cartridge	1	21	Check Clamp	2
8	Gasket	2	22	Check Valve	2
9	Mixer Body	1	23	O-Ring	2
10	Flow Control Valve	1	24	Joint Screw	2
11	O-Ring	1	25	Washer	2
12	Joint	1	26	Wall Cover	2
13	O-Ring	1	27	Cranked Connectors	2
14	Joint	1			

Installation Instructions

- 1) Connect the upper and lower poles, make sure handset holder (18) is fitted.
 - 2) Fit the fixed head to the upper pole
 - 3) Mark out the position of the pole onto the wall
 - 4) Prepare the Hot and Cold supply pipes at 150mm centers.
 - 5) Ensure the holes for the pipes are not made too big as this will affect drilling of the screw holes for the mounting brackets.
 - 6) Ensure that there is approximately 22mm of pipework left exposed proud of the finished tiled wall to establish the correct installation connection.
 - 7) Apply an appropriate amount of sealant between the pipe and wall lining to create a watertight seal.
 - 8) Screw in the cranked connectors so that they are positioned at right angles in front of the wall. This is necessary to avoid spillage from the union nuts. (Cold water on right, hot water on left)
 - 9) Adjust the screwed-in cranked connectors horizontally in line with the spacing of the mixer connections.
 - 10) Screw the wall covers hand-tight onto the cranked connectors towards the wall.
 - 11) At this stage the pipe should be flushed of any debris. Failure to do so may result in the filter of the bar valve becoming prematurely blocked and reduce its performance.
 - 12) If not already integrated in the noise dampers, insert the seals into the union nuts and firmly screw onto the mixer using a smooth spanner (not a spanner with serrated jaws).
 - 13) Connect the flexible shower hose to bar valve bottom outlet
 - 14) Attach the riser rail to bar valve top outlet
 - 15) Turn on the hot and cold water supplies and check for leaks.
- Note: With the aid of the cranked connectors, the inlet pipe centers may vary between 120mm and 180mm.

