

Sales Code: LQ763

Description: Led Mirror H-800 X W-500

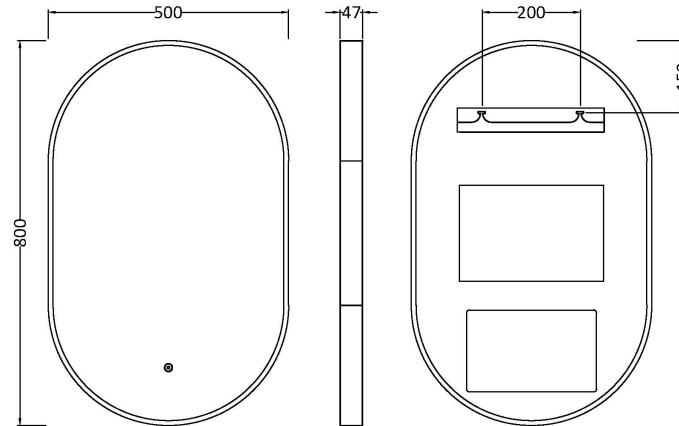

Product Dimensions

Height (mm):	800
Width (mm):	500
Depth (mm):	47
Nett Weight (kg):	6.5

Packaging Dimensions

Height (mm):	105
Width (mm):	600
Depth (mm):	900
Gross Weight (kg):	7

Packaging Data

Box Colour:	Brown Cardboard Box - Printed
Box Qty:	1
Label Size:	x
Label Colour:	
Label Qty:	

Outer Box Dimensions (If Applicable)

Height (mm):	
Width (mm):	
Depth (mm):	
Gross Weight (kg):	
Barcode:	5056678477908

Product Details

Country of Origin:	China		
Fitting Instruction:	No		
Certification: CE & UKCA:	FSC: No	WEEE: Yes	RoHS: Yes
EMC: Yes	LYD: Yes	ECOMP:	ECIRC:
Product Material:	Aluminium		
Colour/Finish:	Silver		
No of Shelves:	0		
Fixings Included:	Yes		
Light Power Source:	Mains Supply		
No of Lights:	2		
Bulb Type:	Led 6000K		
Voltage:	12		
Operation Method:	Touch Sensor		
Bulb Watt:	21		
Product Features:	Demister		
Illuminated:	Yes		