

Coordinated Bathrooms Designed For You

Installation & maintenance instructions

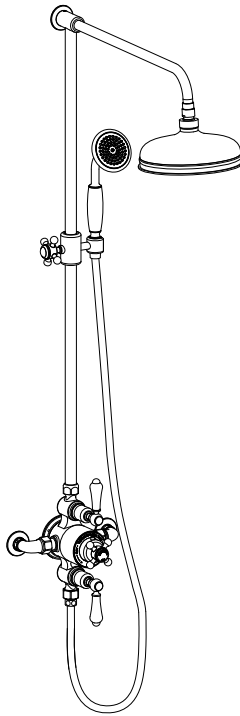

**Grosvenor Exposed Thermostatic valve 2
outlets with Riser & Kit**

CONTENT

IMPORTANT	01
GENERAL INSTALLATION	01
OPERATING SPECIFICATIONS	02
FLOW RATE	03
DIMENSIONS	04
SERVICE PARTS LIST	05
INSTALLATION - STANDARD FIXING	06
INSTALLATION STEPS	07
TROUBLE SHOOTING	10
MAINTENANCE	12
CARE OF THE MIXER	12
REPLACING THE FLOW CARTRIDGE	12
NON RETURN VALVES	13
INSTALLATION THERMOSTATIC CARTRIDGE	13
SERVICING THE THERMOSTATIC CARTRIDGE	14
TEMPERATURE RESETTING	15

IMPORTANT

- Please read these instructions carefully before starting installation and keep for future reference.
- Remove all packaging and check the product for missing parts or damage before starting installation.
- Any alterations made to this product and fittings may infringe water regulations and will invalidate the guarantee.
- The installation must comply with all Local/National Water Supply Authority Regulations/Byelaws and Building and Plumbing (UK:BS6700) Regulations.
- We strongly recommend that you use a qualified and registered plumber.

GENERAL INSTALLATION

-Thermostatic Valves

These fittings are mixing devices and therefore water supplies must be reasonably balanced.

Where connections are made to the mains cold water supply, WRC approved single check valves must be fitted to both hot and cold inlets. This is a stated requirement of Water Supply (Water Fittings) Regulations 1999 Schedule 2, Section 6 Before making any inlet pipe connections, all supply pipes MUST be thoroughly flushed to remove debris. Failure to do so could result in damage or low flow from the mixer unit. Water Supply (Water Fittings) Regulations 1999 Schedule 2 Section 4 G13.1

The fitting of isolating valves to the inlet feeds is advised for ease of maintenance. Please take great care when installing this mixer not to damage its surface.

Operating pressures (on hot and cold line) should be kept as balanced as possible in order to assure optimum efficiency.

Note: When pressure is higher than 5 bar a pressure reducer is required to be fitted before the valve.

Please note if installing in an enclosed environment, access should be left for servicing and maintenance. No costs relating to inadequate access can be accepted.

OPERATING SPECIFICATIONS

Hot Water Supply Temperature:

Maximum: 70° C Minimum: 10° C

Operating Pressure

Maximum: 5 bar Minimum: 0.5 bar

Operation

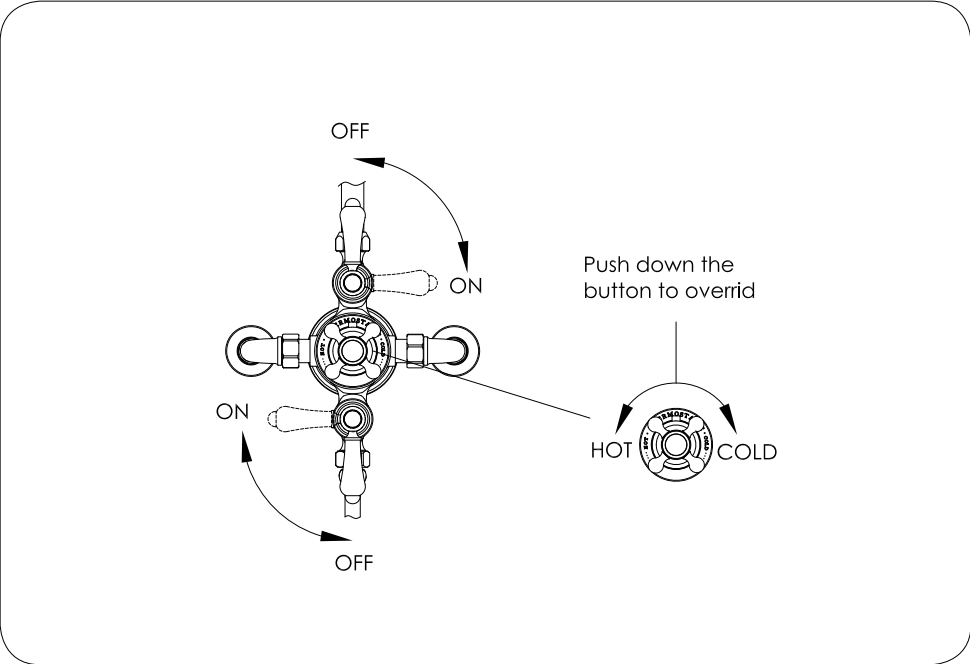

FLOW RATE

38°MIX (L/MIN)	0.5BAR	1BAR	2BAR	3BAR
BODY	9.7	15	22	27.2
HAND SHOWER	5.1	8.2	12	15.3
HEAD SHOWER (With restrictor)	3.8	5.5	7.7	8.3
HEAD SHOWER (Without restrictor)	5.6	8.5	12.6	16

Note:

- Balanced pressures shown are applied directly to the hot and cold inlets; flow rates indicated are free flowing and may vary subject to restrictions created by installation, pipework, layout or application.
- The outlet temperature during testing was 38°C.
- The flow rate indicated is for one outlet only

DIMENSIONS

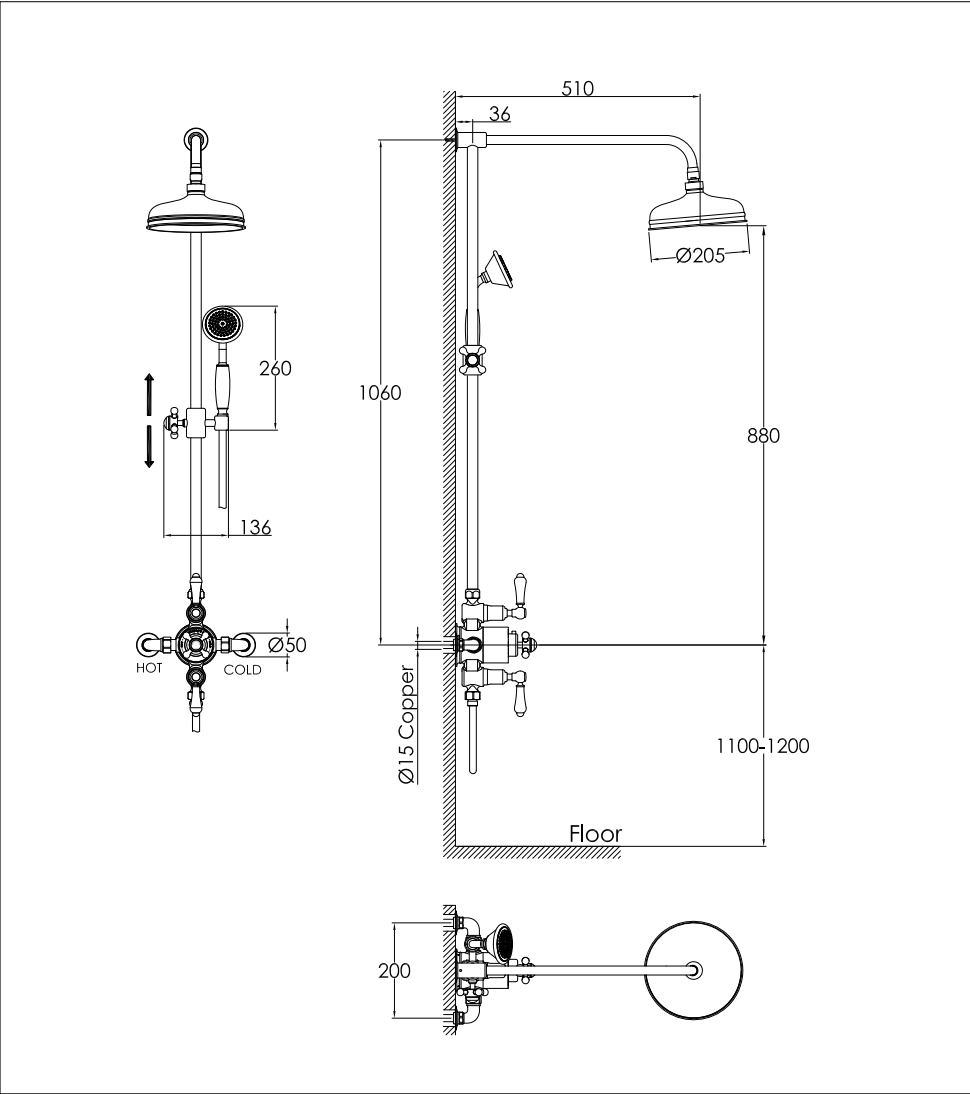

SERVICE PARTS LIST

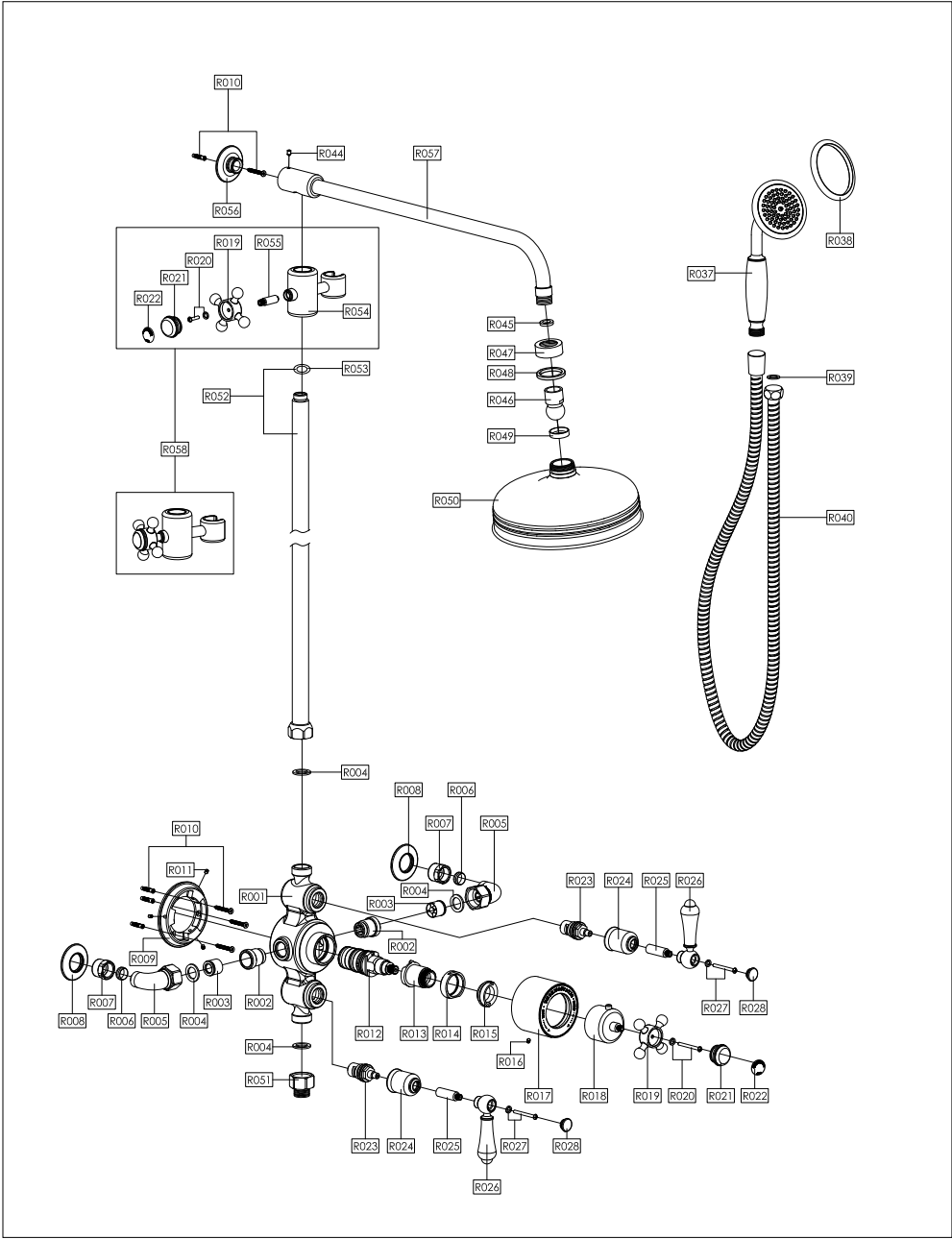

INSTALLATION - STANDARD FIXING

Rinse pipework thoroughly before fitting the valve: do not allow dirt, metal particles or shavings to block the filters fitted on inlets.

Warning! Please check for any hidden cables and pipes before drilling holes in the wall.

WATER SUPPLY CONNECTIONS

Important note:

To ensure correct operation the hot and cold water supplies must be connected to the correct sides of the thermostatic valve. The rear of the valve is fitted with a label indicating the hot and cold inlets. If the orientation of the valve is unclear, the locking washer slot in the valve body located above the thermostatic cartridge can be used to identify the top of the valve. With the slot located above the thermostatic cartridge the hot will be on the left and the cold on the right side of the valve. The hand-wheel, override, thermostatic cartridge cover and locking nut will require removal to view the slot.

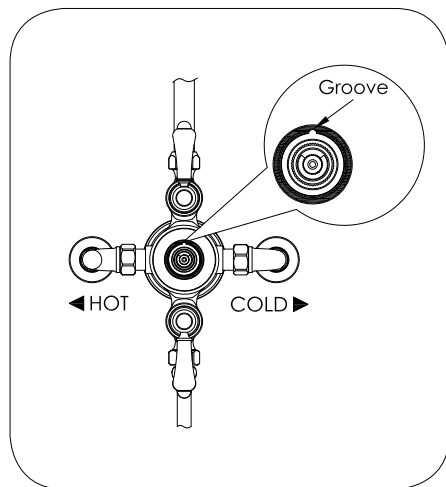

INSTALLATION STEPS

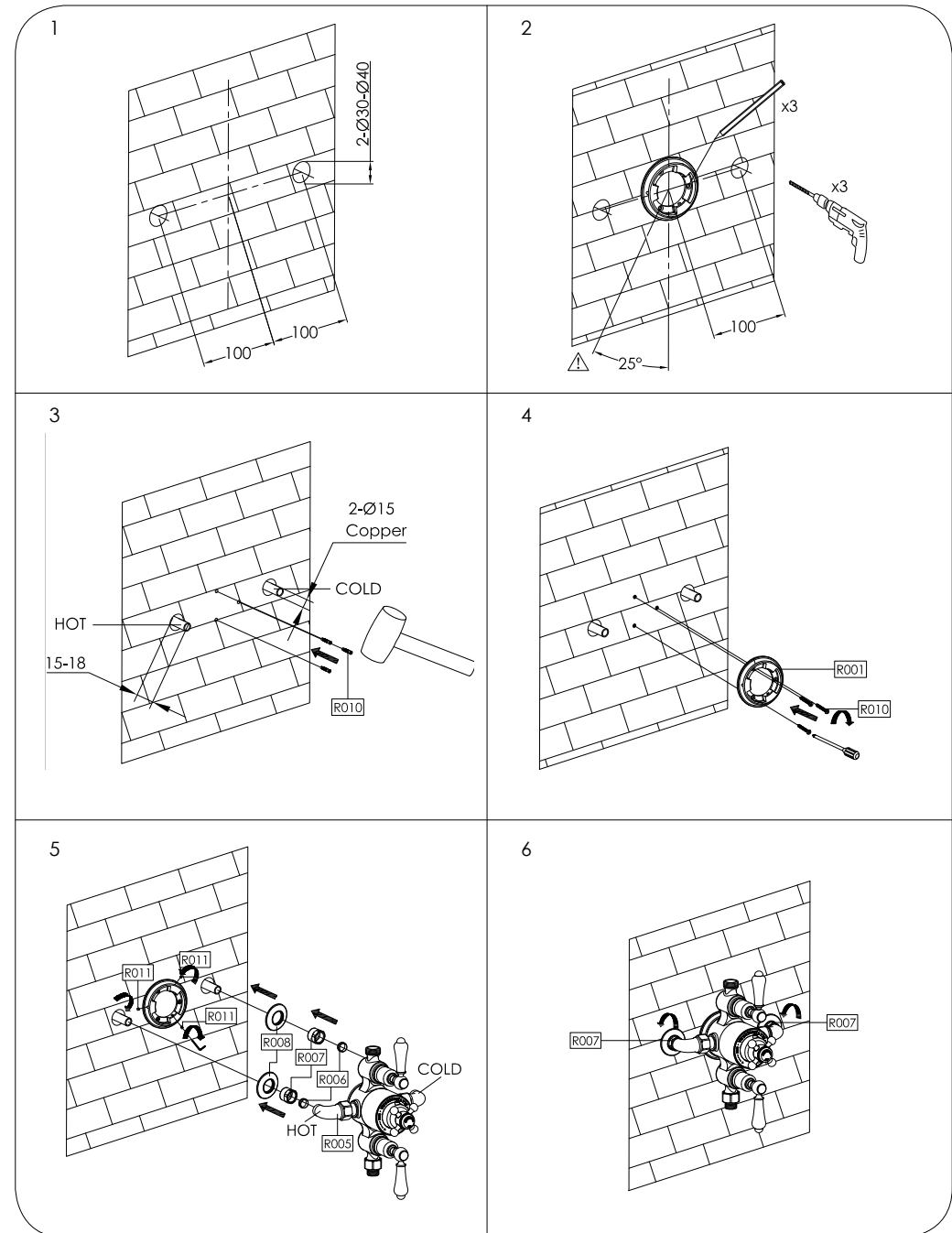

INSTALLATION STEPS

7

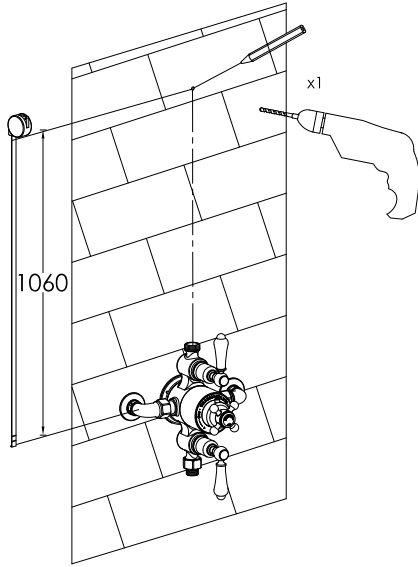

8

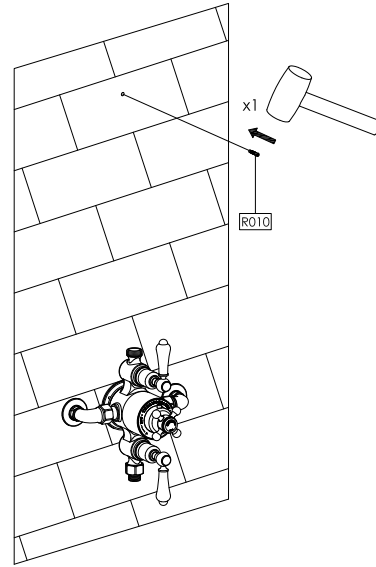

9

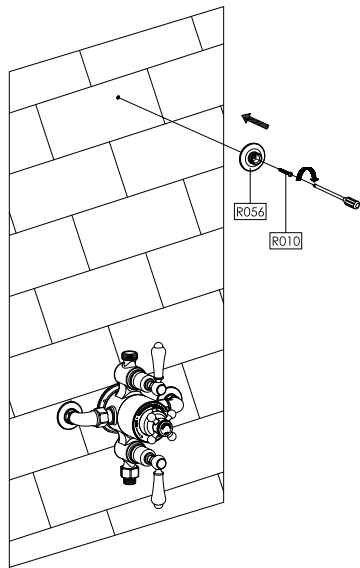

10

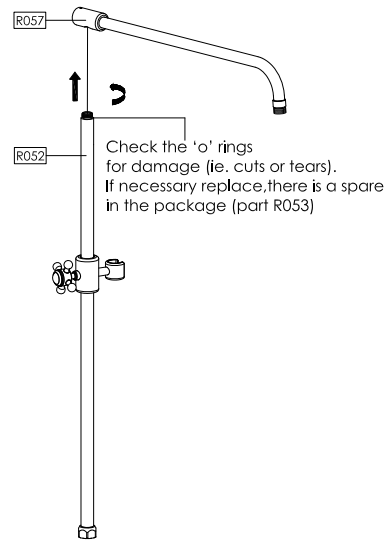

INSTALLATION STEPS

11

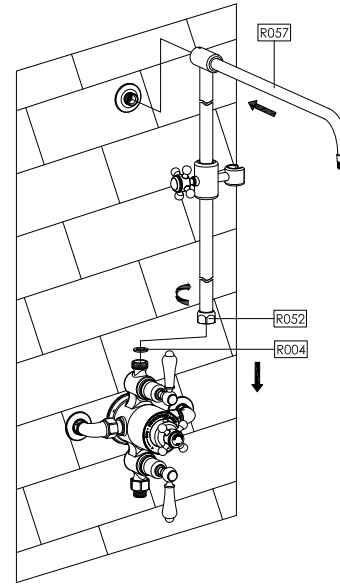

12

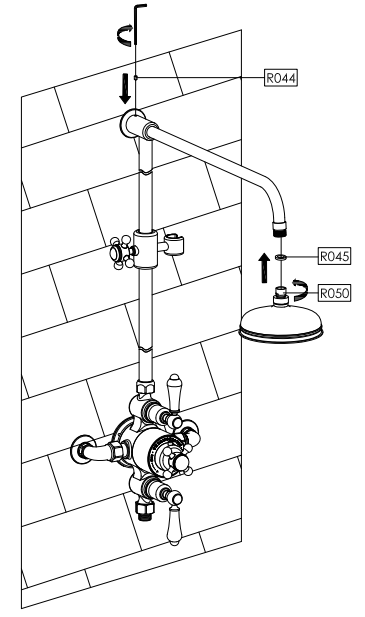

13

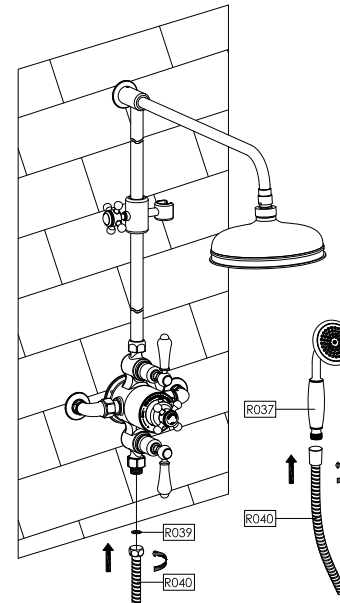

14

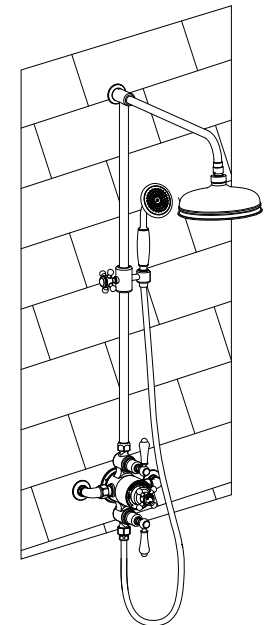

TROUBLE SHOOTING

If you followed the instructions carefully and your mixer still does not work properly, take these corrective steps.

Problem	Possible Cause	Action
Outlet temperature too cold	<ul style="list-style-type: none"> No hot water reaching mixer If the fault has been present since the mixer was installed it is possible that the inlets were installed incorrectly The water supply will be colder in winter months due to outside temperature 	<ul style="list-style-type: none"> Check the water supply for any blockages Check installation-Hot on the left /cold on the right It may be necessary to adjust the hot supply, i.e. increase the hot water temperature setting on boiler
Outlet temperature too hot	<ul style="list-style-type: none"> No cold water reaching mixer If the fault has been present since the mixer was installed it is possible that the inlets were installed incorrectly The water supply will be hotter in summer months due to outside temperature 	<ul style="list-style-type: none"> No cold water reaching mixer Check installation-Hot on the left /cold on the right The water supply will be hotter in summer months due to outside temperature
Only hot or cold water from valve outlet	<ul style="list-style-type: none"> Possible that the inlets have been installed the incorrect way around If only cold water is coming out of the mixer it is possible there is a cartridge fault 	<ul style="list-style-type: none"> Check that the inlets are installed correctly-Hot on the left/cold on the right Remove and check the condition of the thermostatic cartridge

Problem	Possible Cause	Action
Cannot adjust temperature	<ul style="list-style-type: none"> Possible that the cartridge is sticking due to a lime scale build up Over ride temperature manually 	<ul style="list-style-type: none"> Remove the thermostatic cartridge and service Remove the temperature handle by removing the end cap and center retaining screw turn the flow of water on fully and turn the cartridge spindle anti-clockwise to increase the water temperature and clockwise to decrease the water temperature
Poor flow rate	<ul style="list-style-type: none"> Insufficient water pressure Flow valve not fully opening 	<ul style="list-style-type: none"> The required minimum water pressure is 0.5bar(5Mpa) Remove and check the condition of the flow mixer
Water leaking from shower head when the valve is turned off/closed	<ul style="list-style-type: none"> This can be normal for a short period of time after the shower has been used Check that the pressures do not exceed that stated for the product Flow valve leaking 	<ul style="list-style-type: none"> N/A If pressures are too high adjust as necessary, refer to technical data Remove and check the condition of the flow mixer
Water leaking from shower valve / controls	<ul style="list-style-type: none"> Leaking from flow mixer Leaking from thermostatic cartridge Check that the pressures do not exceed that stated for the product 	<ul style="list-style-type: none"> Remove and check the condition of the flow mixer Remove and check the condition of the thermostatic cartridge Check that the pressures do not exceed that stated. If pressures are too high adjust as necessary. Refer to technical data

MAINTENANCE

CARE OF THE MIXER

Our products are finished to the highest standard and due care needs to be taken to ensure their looks are retained.

We recommend cleaning all products with a soft damp cloth **ONLY** and advise strongly against the use of ALL cleaning products i.e. powders and liquids.

If the above instructions are not followed this will invalidate your guarantee in the event of a problem occurring.

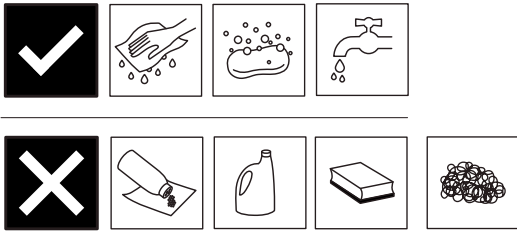

REPLACING THE FLOW CARTRIDGE

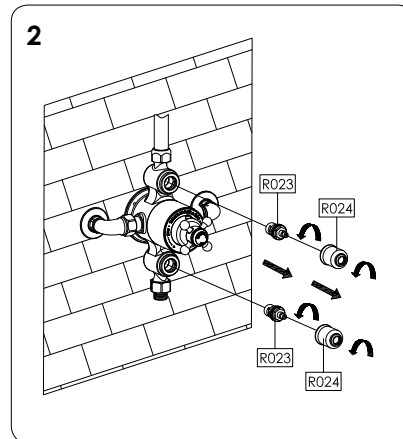
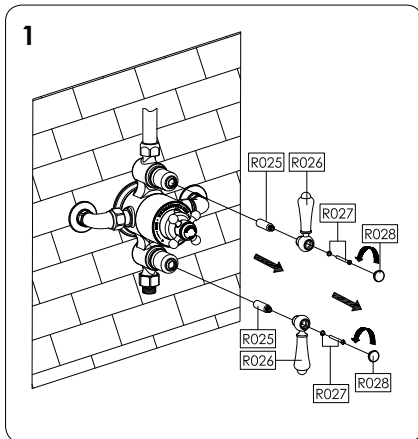

NON RETURN VALVES

- Undo both hex nuts each side of the cartridge using a suitable spanner.
- Pull out the non return valve, rinse in water to remove the dirt, and then soak them in vinegar or descaling agent. Grease the 'O' rings using a suitable silicone lubricant and replace.

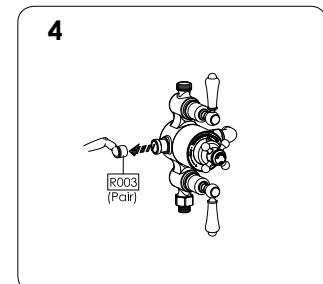
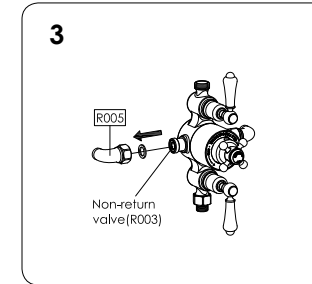
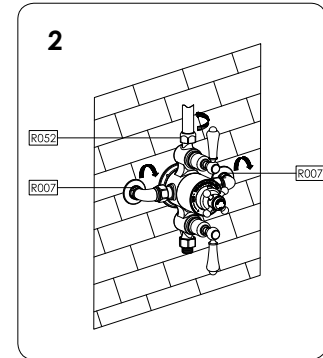
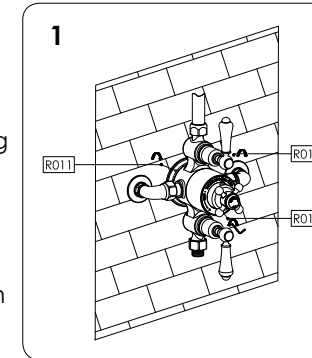

Installation Thermostatic cartridge

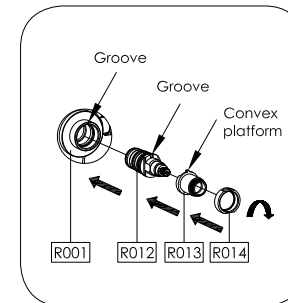

SERVICING THE THERMOSTATIC CARTRIDGE

If after a period of time you experience temperature problems with your shower valve, particularly if you are in a hard water area, it is quite common for limescale deposits to have formed in the thermostatic cartridge. We recommend you remove the cartridge and soak it in a descaling fluid which normally resolves the problem. It is difficult to set a regular servicing time scale as it is subject to water conditions and usage.

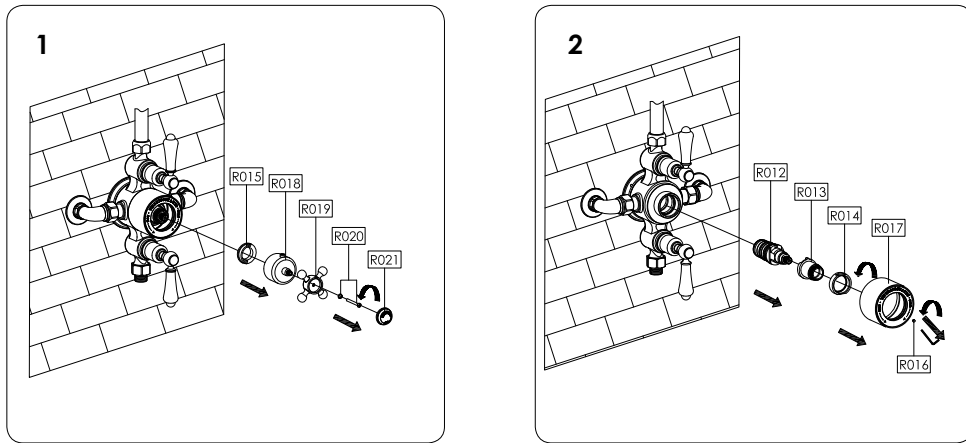

Check the 'o' rings for damage (ie. cuts or tears). Remove the 'o' rings before soaking the cartridge in descaling fluid. Soak the cartridge according to the instructions on the descaling fluid packaging. Rinse under cold water before fitting (refer to the 'installing the thermostatic cartridge' section to install).

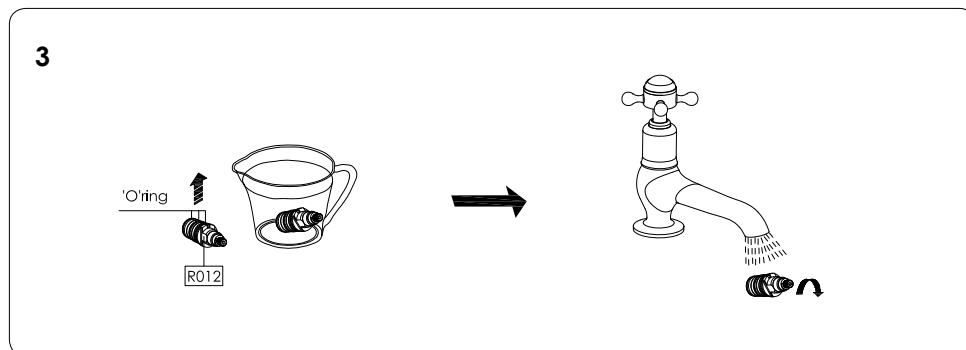

TEMPERATURE RESETTING

The valve has been factory set under balance pressures and hot water supply at 65° C. When your specific operating conditions are significantly different from the above, the temperature of the water may vary from the setting.

When the difference is too great, you can adjust the calibration of the valve to suit individual requirements of the installation:

1. Select 38° C or the arrow on the handle and check the temperature of the water being delivered to the outlet with a thermometer.
 2. If the temperature is unacceptable proceed to reset the calibration as follows: Remove the handle. Do not remove the plastic stop ring. Turn the spline of the valve clockwise to decrease the temperature and anti-clockwise to increase the temperature until 38° is achieved at outlet.
 3. Ensure that the stop on the stop ring is at 12 o'clock and replace the handle with the temperature override button also pointing at 12 o'clock being careful not to turn the spline of the valve, replace the handle.
- Our valve setting is now calibrated.

