

## Rimless close coupled Doc M toilet pack, stainless steel, concealed fixings



### Product details

<b>Warranty:</b>	See individual products
<b>Maximum load:</b>	See individual products
<b>Doc M compliant:</b>	Yes
<b>Suitable for wet areas:</b>	Yes

### Features

- Complies with Part M of the Building Regulations
- Inlet valve and syphon Reg 4 Certified (WRAS, NSF, Kiwa, etc.)
- Hygienic rimless pan with robust dedicated seat
- Concealed fixing stainless steel grab rails
- Optional TMV3 valve (F21-CCTX-SSC-\*\* & -CCTL-)
- Optional lockable cistern (F21-CCLX-SSC-\*\* & -CCTL-)
- Universal - suitable for left or right-handed transfer
- Simple one box solution

### Finish options



White  
RAL 9016



Dark blue  
RAL 5011



Dark grey  
RAL 7016



Grey  
RAL 7005



Satin  
Stainless Steel



Polished  
Stainless Steel

### Product description

Rimless close coupled Doc M toilet pack, stainless steel, concealed fixings

Rimless close coupled Doc M toilet pack, lockable cistern lid, stainless steel, concealed fixings

Rimless close coupled Doc M toilet pack, stainless steel, concealed fixings, TMV3 valve

Rimless close coupled Doc M toilet pack, lockable cistern, stainless steel, concealed fixings, TMV3 valve

### Product code

F21-CCXX-SSC-\*\*

F21-CCLX-SSC-\*\*

F21-CCTX-SSC-\*\*

F21-CCTL-SSC-\*\*

Replace \*\* with finish option code above e.g., F21-CCXX-SSC/DB

## Pack contents

- 4 x 600mm stainless steel grab rails with concealed fixings
- 1 x 450mm stainless steel grab rail with concealed fixings
- 1 x 800mm stainless steel hinged support rail
- 1 x Close coupled rimless Doc M pan
- 1 x Close coupled cistern (optional lockable lid)
- 1 x Close coupled cistern fittings and Doc M spatula lever
- 1 x Ring only toilet seat
- 1 x Two tap hole basin
- 1 x Sequential basin mixer tap
- 1 x Tap hole stopper
- 1 x Basin waste
- 1 x TMV3 Valve (F21-CCTL-SSC-\*\* & F21-CCTX-SSC-\*\*)

## Dimensions (mm)

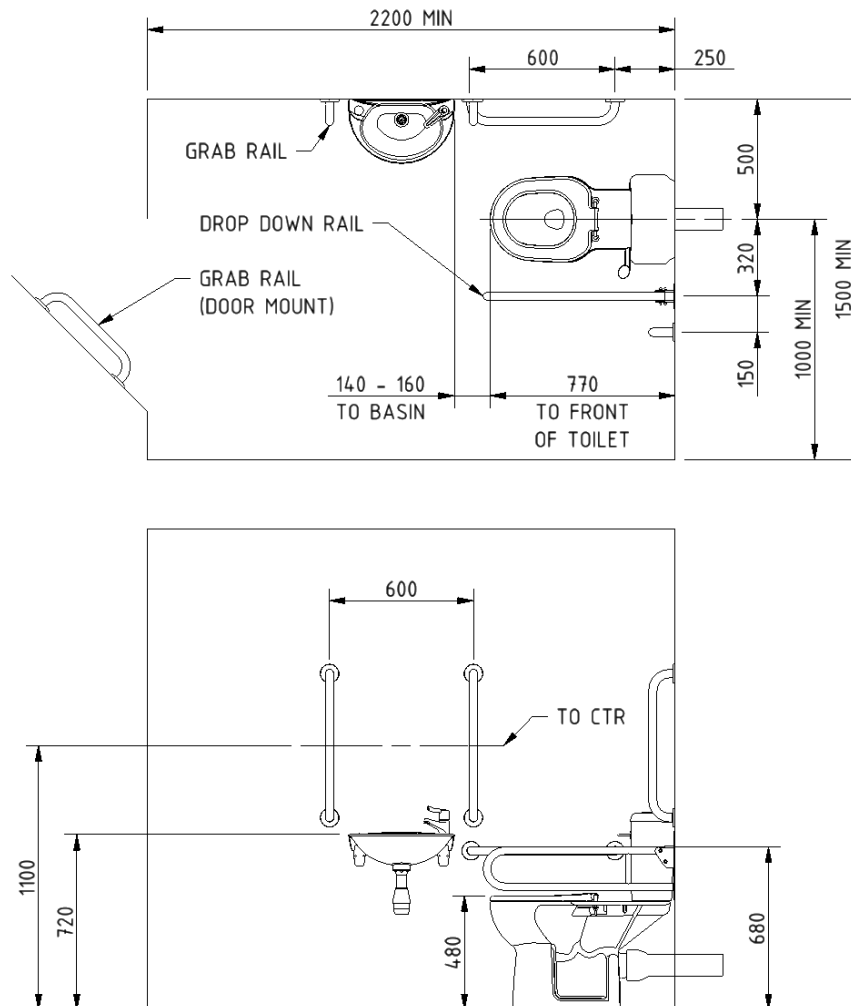

## Disclaimer

NYMAS Group makes every effort to ensure that the information provided on this data sheet is correct. However, we cannot guarantee this, and accept no liability for any information or advice given on this data sheet.

## Close coupled rimless Doc M pan



### Product details

<b>Warranty:</b>	Lifetime
<b>Maximum load:</b>	400 kg
<b>Doc M compliant:</b>	Yes
<b>Suitable for wet areas:</b>	Yes

### Features

- Extended projection to comply with Part M of the Building Regulations
- Rimless design for ease of cleaning
- Comfort height to allow easier side transfer from wheelchair
- UKCA & CE compliant
- Ceramic body

### Finish options

**WH**

White  
RAL 9016

### Product description

Close coupled rimless Doc M pan

### Product code

NY01-PANCC02-WH

### Disclaimer

NYMAS Group makes every effort to ensure that the information provided on this data sheet is correct. However, we cannot guarantee this, and accept no liability for any information or advice given on this data sheet.

Dimensions (mm)

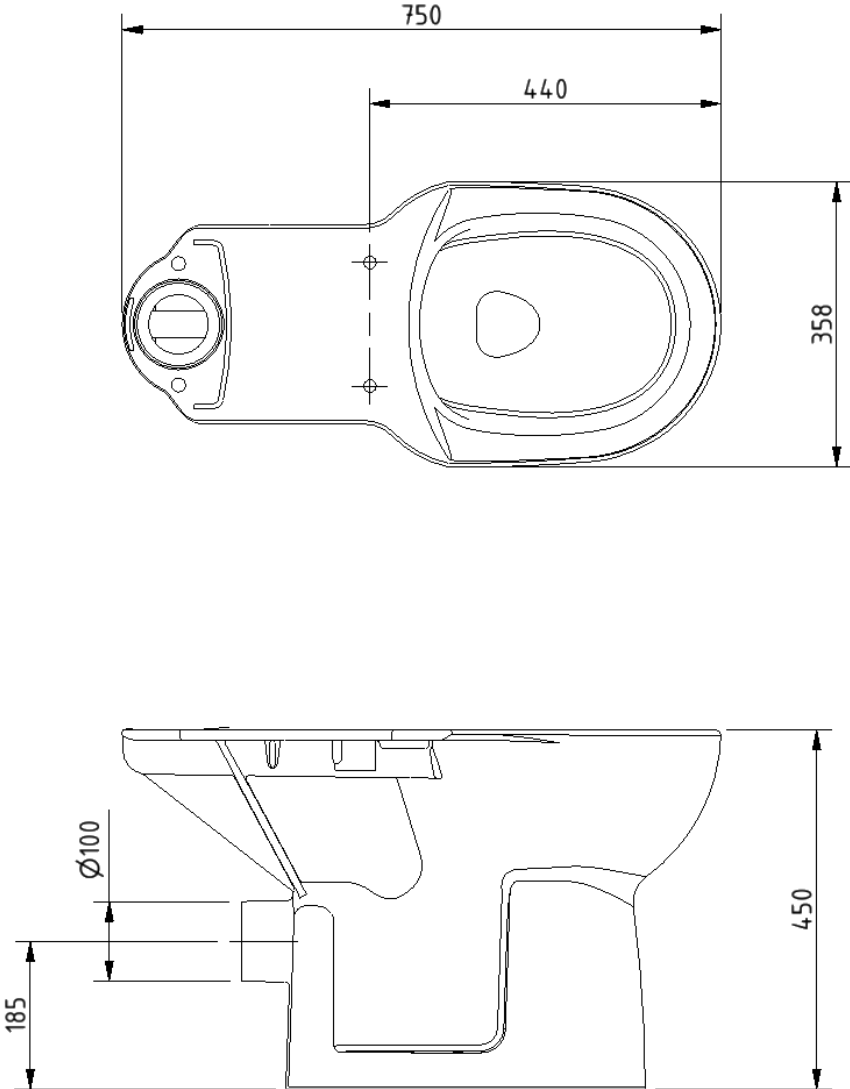

## Close coupled minimal cistern tank



### Product details

<b>Warranty:</b>	Lifetime
<b>Max rated load:</b>	n/a
<b>Doc M compliant:</b>	Yes
<b>Suitable for wet areas:</b>	Yes

### Features

- Modern minimal design
- Complies with Part M of the Building Regulations
- UKCA & CE compliant
- Suitable for front lever
- Bottom inlet
- Universal - either left or right handed
- Lockable lid option

### Finish options

**WH**

White  
RAL 9016

### Product description

Minimal close coupled cistern, white

Minimal close coupled cistern with lockable lid, white

### Product code

BWCISTCC-SAN

BWCISTCC/LC-SAN

### Disclaimer

NYMAS Group makes every effort to ensure that the information provided on this data sheet is correct. However, we cannot guarantee this, and accept no liability for any information or advice given on this data sheet.

## Dimensions (mm)

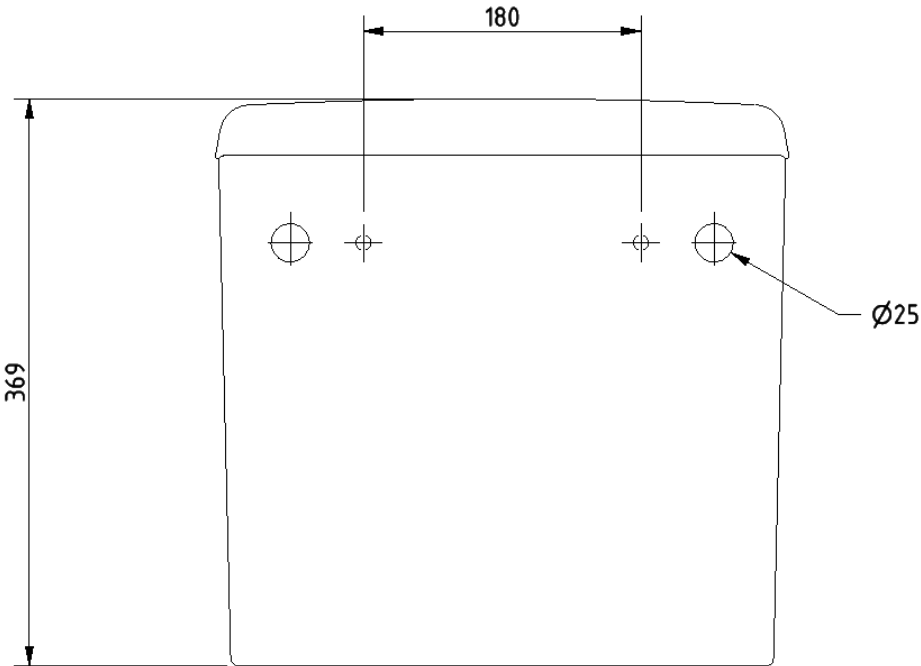
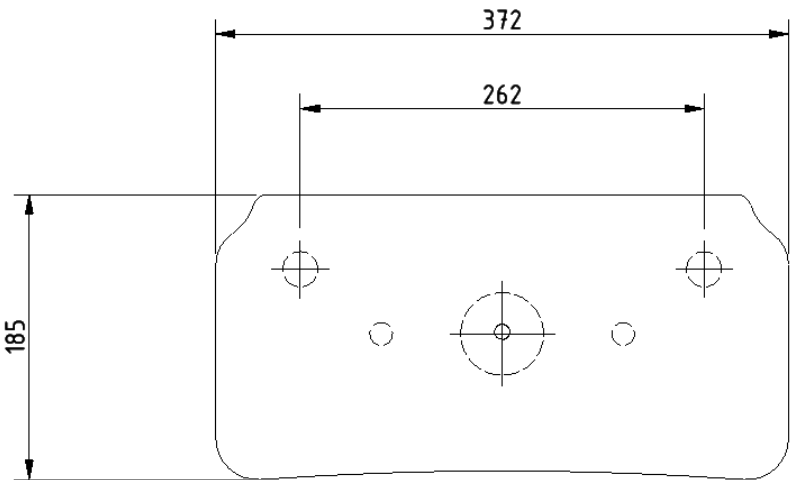

## Compact Doc M basin



### Product details

<b>Warranty:</b>	Lifetime
<b>Max rated load:</b>	n/a
<b>Doc M compliant:</b>	Yes
<b>Suitable for wet areas:</b>	Yes

### Features

- Two tap holes for left or right handed configuration
- Compact design to maximise space for a wheelchair user
- Complies with Part M of the Building Regulations
- No overflow

Does not come with wall fixings (P-000248-X00X)

## Finish options

**WH**

White  
RAL 9016

## Product description

Compact Doc M basin, two tap holes, no overflow, white

## Product code

NY01-SW-00120-WH

## Disclaimer

NYMAS Group makes every effort to ensure that the information provided on this data sheet is correct. However, we cannot guarantee this, and accept no liability for any information or advice given on this data sheet.

**Dimensions (mm)**

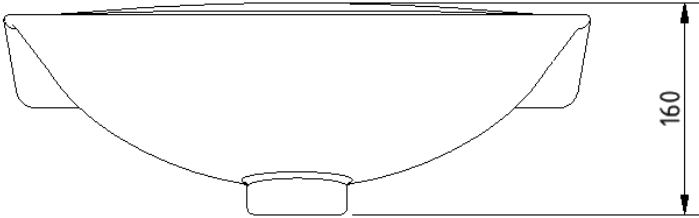
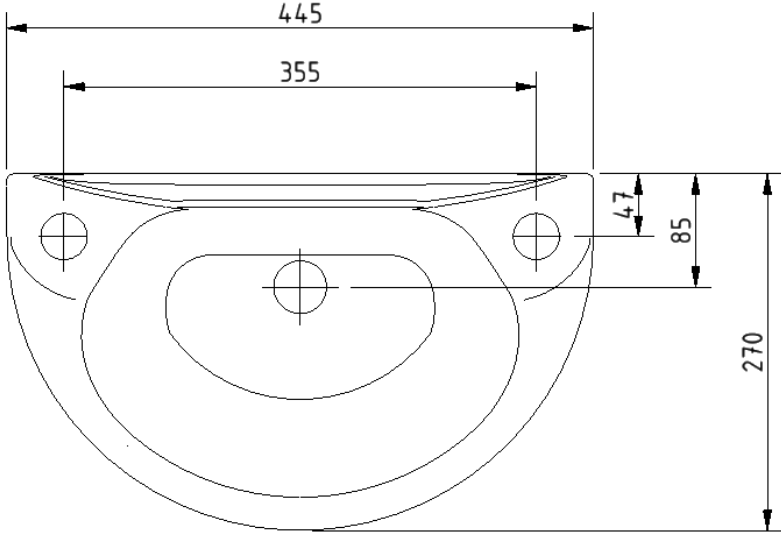



**Dimensions (mm)**

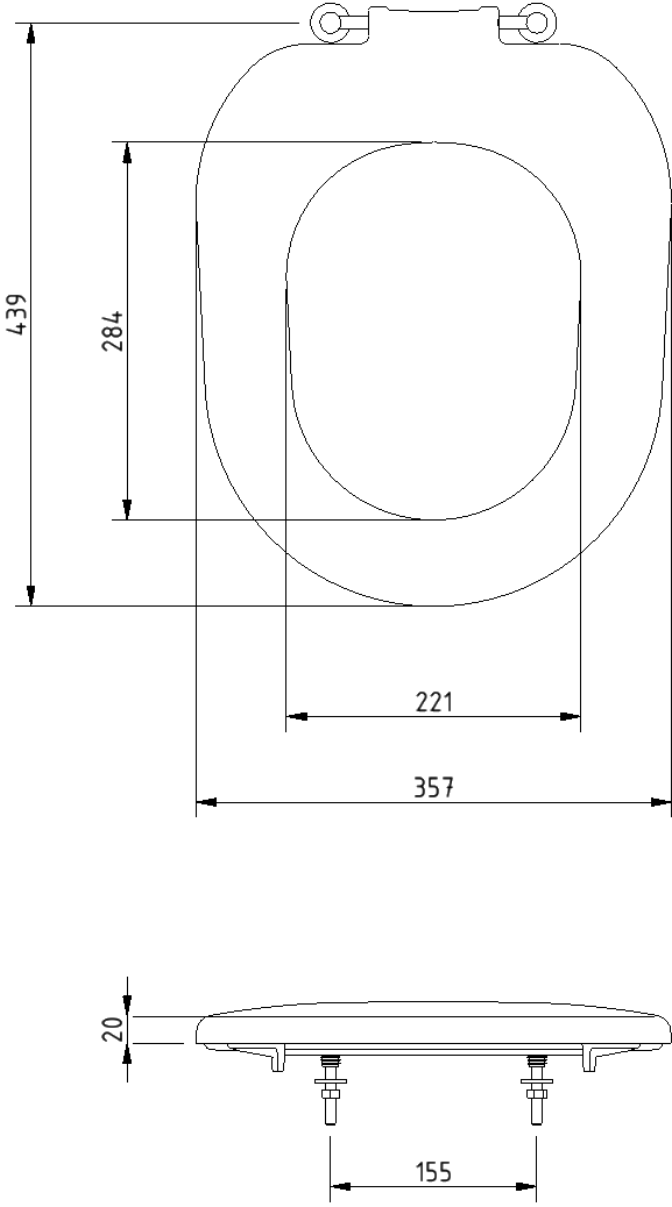

## Compact Doc M basin



### Product details

<b>Warranty:</b>	Lifetime
<b>Max rated load:</b>	n/a
<b>Doc M compliant:</b>	Yes
<b>Suitable for wet areas:</b>	Yes

### Features

- Two tap holes for left or right handed configuration
- Compact design to maximise space for a wheelchair user
- Complies with Part M of the Building Regulations
- No overflow

Does not come with wall fixings (P-000248-X00X)

## Finish options

**WH**

White  
RAL 9016

## Product description

Compact Doc M basin, two tap holes, no overflow, white

## Product code

NY01-SW-00120-WH

## Disclaimer

NYMAS Group makes every effort to ensure that the information provided on this data sheet is correct. However, we cannot guarantee this, and accept no liability for any information or advice given on this data sheet.

Dimensions (mm)

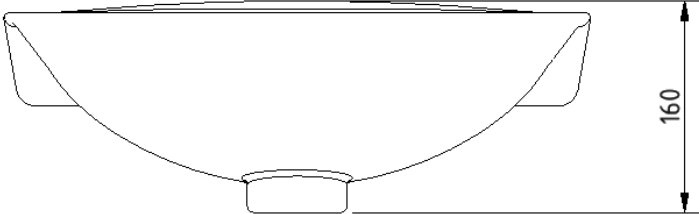
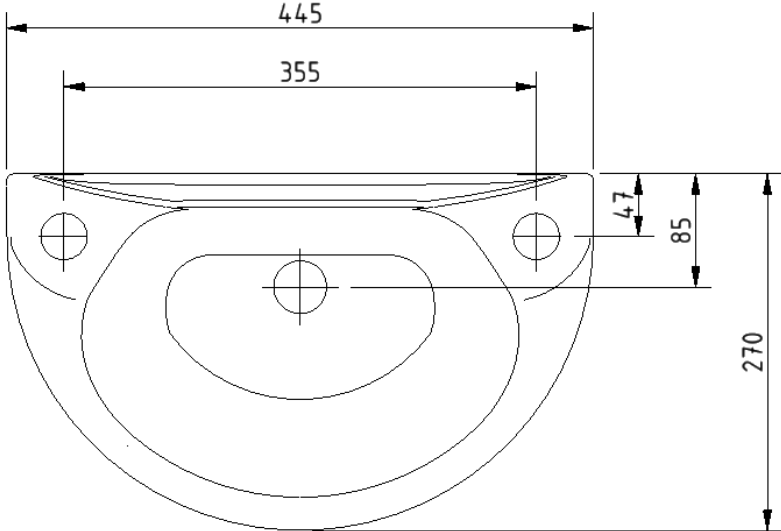

## Polished chrome sequential basin mixer tap



### Product details

<b>Warranty:</b>	2 years
<b>Max rated load:</b>	n/a
<b>Doc M compliant:</b>	Yes
<b>Suitable for wet areas:</b>	Yes
<b>Flexi tap tail connection (to tap body):</b>	M10 Thread
<b>Flexi tap tail (onward connection):</b>	3/4 Inch Diameter Thread

### Features

- Reg 4 Certified (WRAS, NSF, Kiwa, etc.)
- Easy operation for users with limited dexterity
- Cold start

### Finish options



Polished chrome

### Product description

Sequential basin mixer tap, polished chrome

### Product code

BPLMON

### Disclaimer

NYMAS Group makes every effort to ensure that the information provided on this data sheet is correct. However, we cannot guarantee this, and accept no liability for any information or advice given on this data sheet.

## Dimensions (mm)

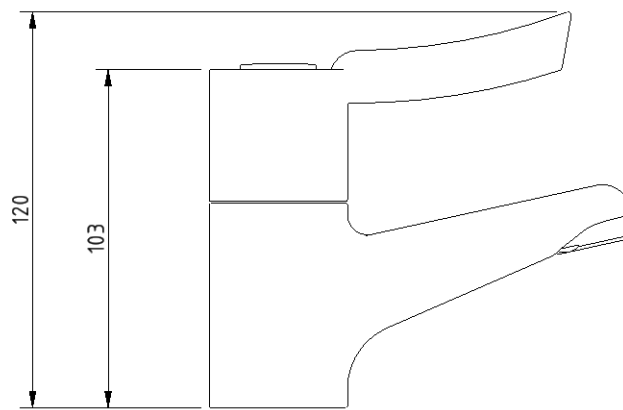
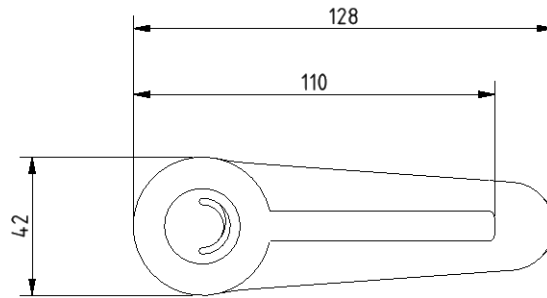

## Flow Rate Curve

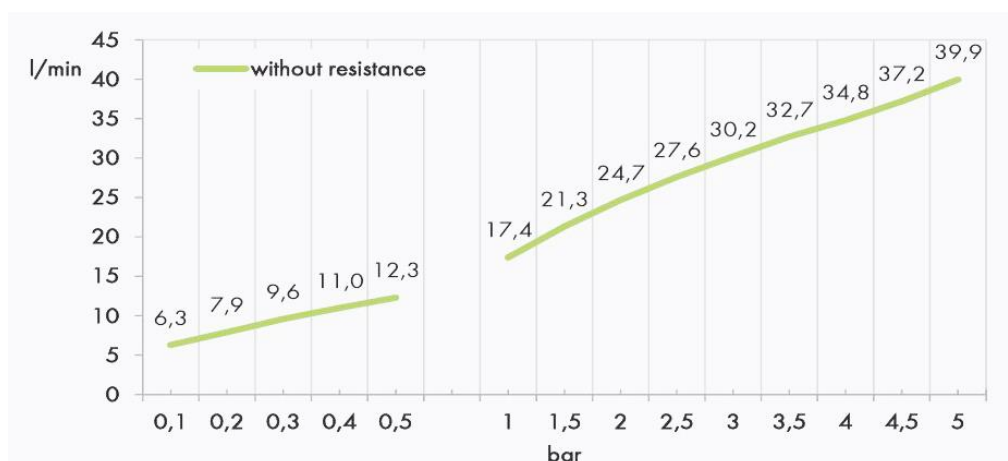

Procedure:

Flow Determination

Pressure:

3,0 Bar

Cold:

18,9 l/min

Hot:

19 l/min

To 38 deg C:

26 l/min

## Basin hanging brackets



### Product details

**Warranty:** 2 years

**Max rated load:** n/a

**Doc M compliant:** n/a

**Suitable for wet areas:** No

### Features

- Basin hanging brackets for compact Doc M basin (NY01-SW-00120-WH)
- Strong steel construction

### Product description

Basin hanging brackets

### Product code

P-000248-X00X

### Disclaimer

NYMAS Group makes every effort to ensure that the information provided on this data sheet is correct. However, we cannot guarantee this, and accept no liability for any information or advice given on this data sheet.

## Dimensions (mm)

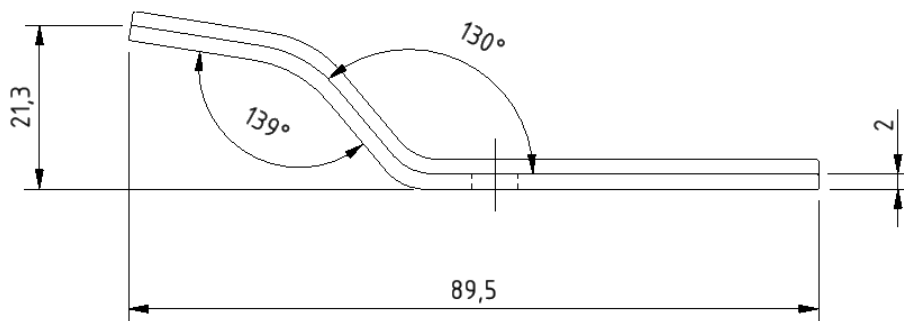
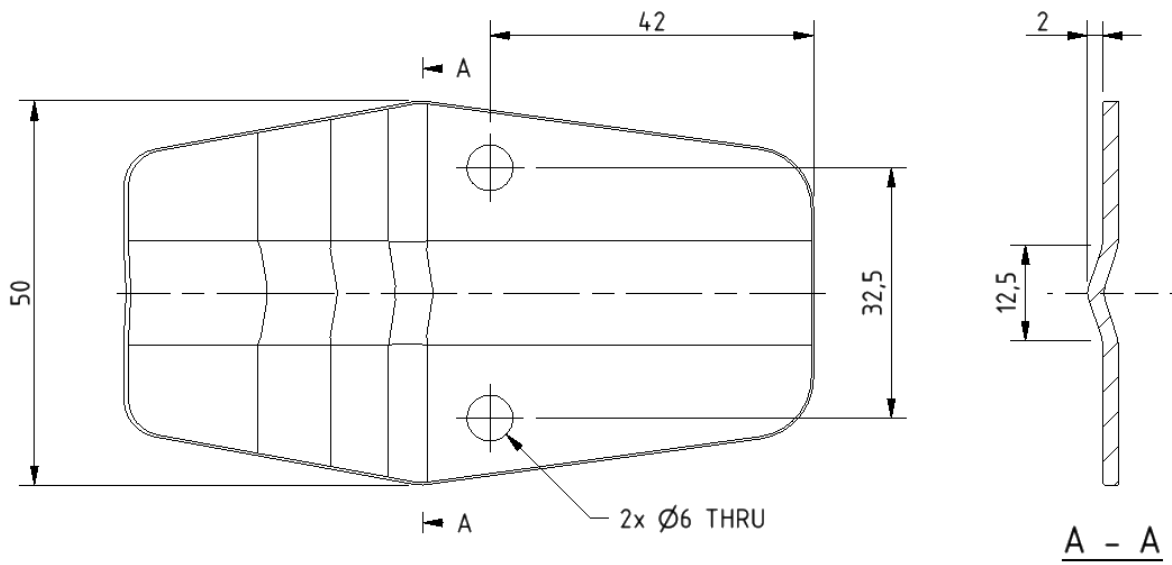

## Stainless steel grab rail with concealed fixings, 35mm diameter tube



### Product details

<b>Warranty:</b>	5 years
<b>Max rated load:</b>	185 kg
<b>Doc M compliant:</b>	Yes
<b>Suitable for wet areas:</b>	Yes

### Features

- Non-corrosive stainless steel construction
- Durable powder coated finish
- Concealed fixing
- Non-standard colour options available

### Finish options



**White**  
RAL 9016



**Dark blue**  
RAL 5011



**Dark grey**  
RAL 7016



**Grey**  
RAL 7005

### Product description

Grab rail, stainless steel, concealed fixings, 35mm diameter, 300mm
Grab rail, stainless steel, concealed fixings, 35mm diameter, 450mm
Grab rail, stainless steel, concealed fixings, 35mm diameter, 600mm
Grab rail, stainless steel, concealed fixings, 35mm diameter, 900mm

### Product code

210130/**
210145/**
210160/**
210190/**

Replace \*\* with finish option code above e.g., 210160/DB

### Disclaimer

NYMAS Group makes every effort to ensure that the information provided on this data sheet is correct. However, we cannot guarantee this, and accept no liability for any information or advice given on this data sheet.



## Dimensions (mm)

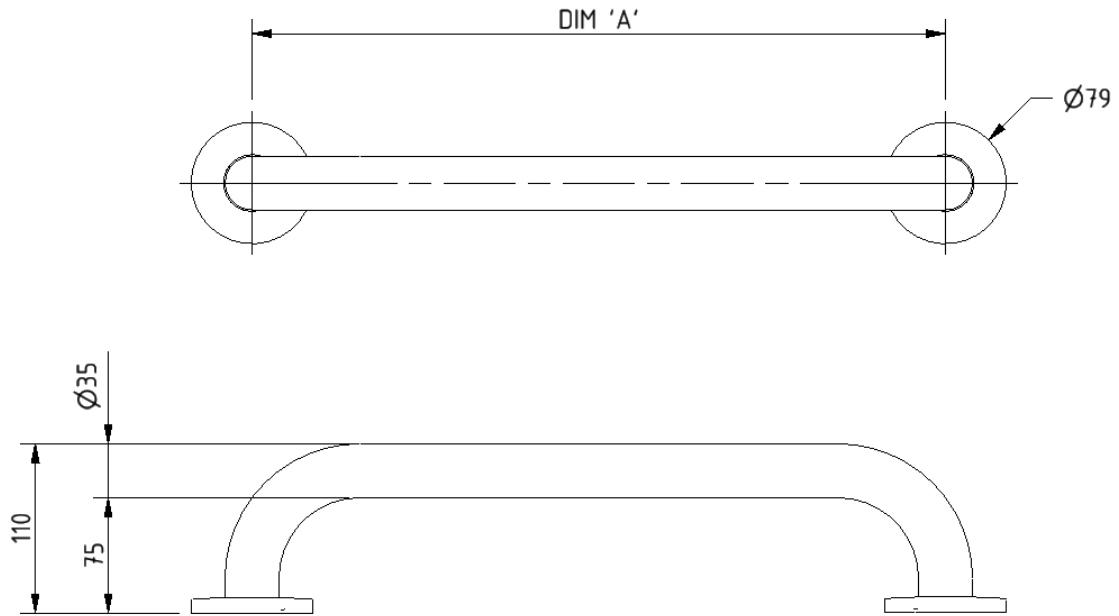

PRODUCT CODE	210130/**	210145/**	210160/**	210190/**
DIM 'A'	300	450	600	900

## Stainless steel lift and lock hinged support rail



### Product details

Warranty:	5 years
Max rated load:	135 kg
Doc M compliant:	Yes
Suitable for wet areas:	Yes

### Features

- Complies with Part M of the Building Regulations
- Lift and lock folding mechanism
- Non-corrosive stainless steel construction
- Toilet roll holder (optional)

### Finish options



White  
RAL 9016



Dark blue  
RAL 5011



Dark grey  
RAL 7016



Grey  
RAL 7005



Satin  
Stainless Steel



Polished  
Stainless Steel

### Product description

Hinged lift and lock support rail, stainless steel, 650mm  
Hinged lift and lock support rail, stainless steel, 800mm,

### Product code

211865/\*\*  
211880/\*\*

Replace \*\* with finish option code above e.g., 211880/DB

### Disclaimer

NYMAS Group makes every effort to ensure that the information provided on this data sheet is correct. However, we cannot guarantee this, and accept no liability for any information or advice given on this data sheet.

## Dimensions (mm)

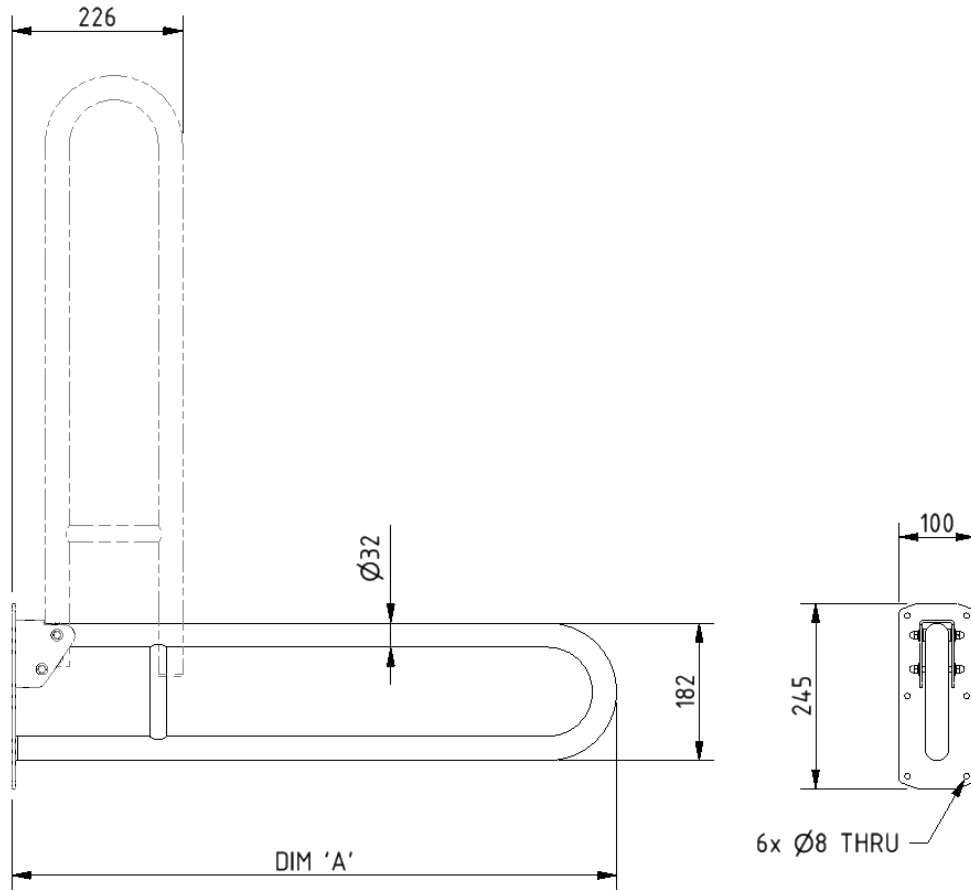

PRODUCT CODE	211865/**	211880/**
DIM 'A'	650	800

## TMV3 inline thermostatic mixing valve



### Product details

<b>Warranty:</b>	2 years
<b>Max rated load:</b>	n/a
<b>Doc M compliant:</b>	Yes
<b>Suitable for wet areas:</b>	Yes

### Features

- TMV3 approved & Reg 4 Certified (WRAS, NSF, Kiwa, etc.)
- Complies with Part M of the Building Regulations
- Building Regulations Part G compliant
- Highly resistant to scaling
- Anti-tamper proof head

### Finish options



**CP**

Polished  
chrome

### Product description

TMV3 inline thermostatic mixing valve - 15mm

### Product code

BPLTMV

### Disclaimer

NYMAS Group makes every effort to ensure that the information provided on this data sheet is correct. However, we cannot guarantee this, and accept no liability for any information or advice given on this data sheet.

Dimensions (mm)

