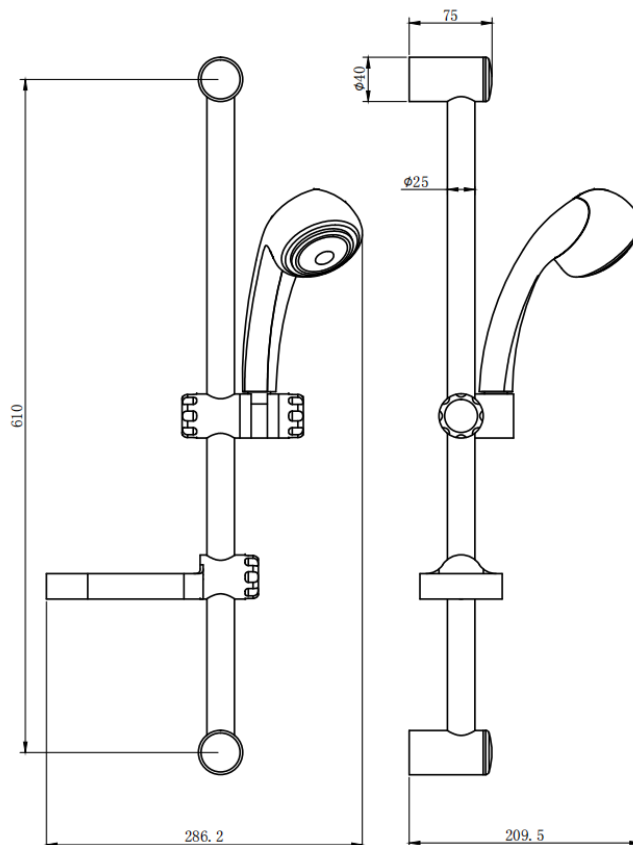

**SHO060FL- Flow Slide Rail Kit****BAR CODE: 5055681401610****COLOUR: CHROME****WEIGHT:****NET 0.77 kg****GROSS 1.09 kg****BOX SIZE 690X160X90**