

SHO002PL- Plan concealed thermostatic shower valve+diverter



BAR CODE: 5055681401450

COLOUR: CHROME

WEIGHT:

NET 2.5 kg

GROSS 2.86 kg

STANDARDS: BS EN 1111

NOTES:

SUITABLE FOR PRESSURES BETWEEN 0.2 - 5 BAR

HOT & COLD PRESSURES MUST BE BALANCED

SUITABLE FOR COMBI- BOILERS, UNVENTED MAINS

PRESSURE SYSTEMS AND GRAVITY FED SYSTEMS

SUITABLE FOR SHOWER PUMPS

Flow Rate:

0.2 bar	0.5 bar	1 bar	2 bar	3 bar	5 bar
5.1 L	7.6L	11.6 L	17 L	21 L	25.9 L

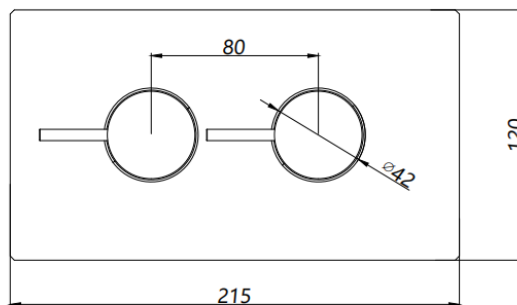
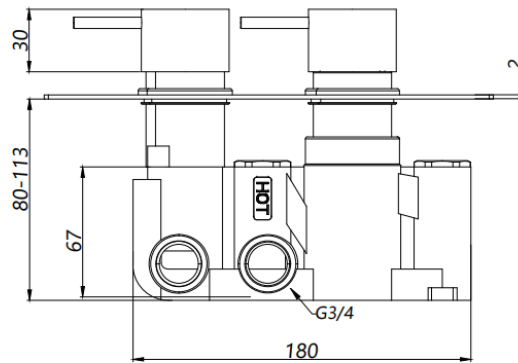

BOX SIZE 263x165x160