

ASSEMBLY INSTRUCTIONS FOR GOLD OR CHROME
PLATED 1/4" BASIN BOTTLE TRAPS

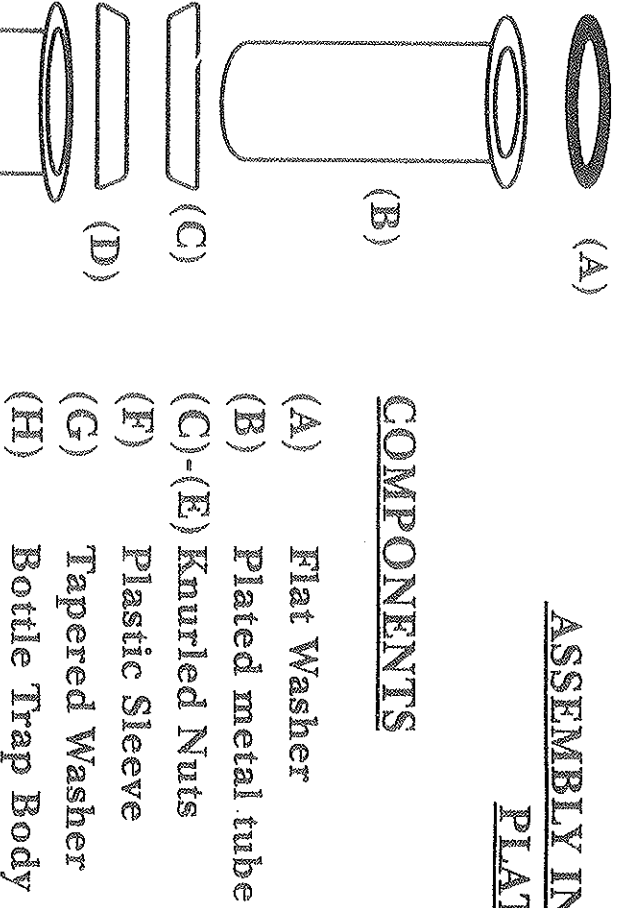

COMPONENTS

1. Assemble Knurled nut (C) onto the plated metal tube (B) under the top flange with the wide end facing upwards to receive the waste assembly. Slide the knurled nut (D) over the plated tube, with the wide end facing down.

2. Push the plastic sleeve (F) into the top of the bottle trap main body (H) ensuring the lip seats on the neck of the trap. Insert the metal tube into the centre of the plastic sleeve and lock the knurled nut (D) firmly into position.

3. This trap is designed to connect to standard 1/4" metal waste pipe (35 mm outside diameter). Slide the knurled nut (E) and tapered washer (G) over the waste pipe as shown. Insert pipe into the trap outlet and tighten the nut.

4. When fitted onto a basin waste outlet the washer (A) must be placed inside the knurled nut (C) to form a seal between the trap and waste.

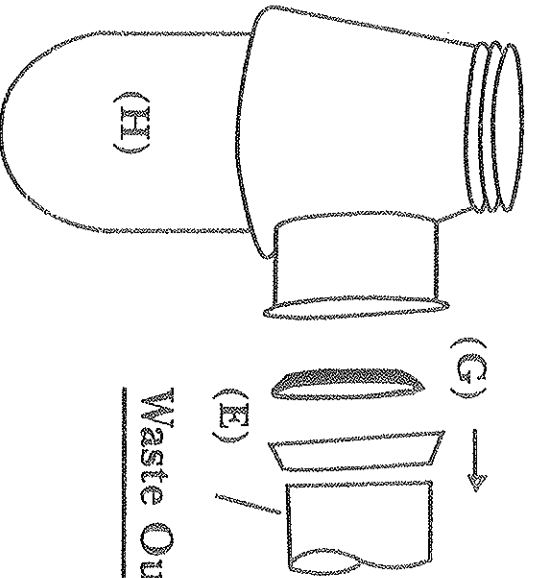

Waste Outlet Pipe