



Collection: S20

### Technical specifications

<b>Colour</b>	White
<b>Height</b>	170
<b>Width</b>	550
<b>Depth</b>	445
<b>Designer</b>	Noa
<b>Finish</b>	Hygiene
<b>Material</b>	Hygiene

<b>Overflow Hole</b>	With Overflow
<b>Packaged Product</b>	585X200X495
<b>Sizes (WxDxH)</b>	
<b>Certificate</b>	CE
<b>Body Material</b>	FFC- Fire Fine Clay
<b>Countertop Usage</b>	Half counter
<b>Overflow Hole Detail</b>	With Overflow
<b>Tap Hole Options</b>	Double Tap Holes
<b>Ceramic Sanitaryware</b>	

<b>Guarantee</b>	10
<b>Drainer</b>	Not included
<b>Syphon</b>	Syphon Not Included
<b>Marketing Measure (cm)</b>	55 x 44 CM

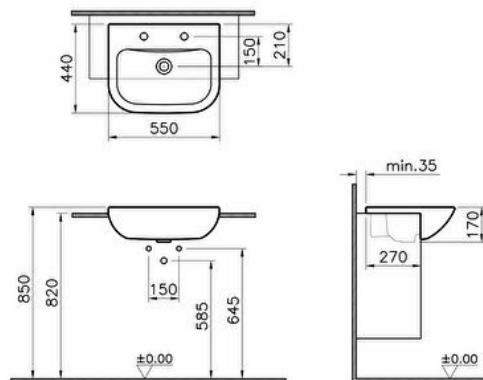
**2A technical drawing****Technical specifications**

**Colour:** White **Height:** 170 **Width:** 550 **Depth:** 445 **Designer:** Noa **Finish:** Hygiene **Material:** Hygiene **Overflow Hole:** With Overflow **Packaged Product Sizes (WxDxH):** 585X200X495 **Certificate:** CE **Body Material:** FFC- Fire Fine Clay **Countertop Usage:** Half counter **Overflow Hole Detail:** With Overflow **Tap Hole Options Ceramic Sanitaryware:** Double Tap Holes **Guarantee:** 10 **Drainer:** Not included **Syphon:** Syphon Not Included **Marketing Measure (cm):** 55 x 44 CM